

# Computer Graphics

Karin Kosina (vka kyrah)

OpenGL

# Open Graphics Library

# OpenGL

- a platform-independent API for 2D and 3D graphics applications
- a standard, not a library
- various implementations (e.g. by graphics card vendors) with varying degrees of optimisation
- Input: primitives (polygons, lines, points)
- Output: pixels
- low-level
- state-machine
- only does rendering
- need additional framework for OS integration, image loading,...

# The Rendering Pipeline

# Concepts

- Pipelines? Think of oil pipelines, assembly lines, ski lifts,...
- Pipelines consist of stages.
  - In an oil pipeline, the oil passes through sequentially.
  - The speed of the pipeline is determined by the slowest part of the pipeline, no matter how fast the other stages may be.
- Ideally, a pipeline of  $n$  stages should give a speed-up of factor  $n$ 
  - assembly line is a good example

# Concepts

- Pipeline stages are executed in parallel, but they are stalled until the slowest stage has finished its task.
- cf. a car factory assembly line:
  - attaching the steering wheel takes 3 minutes
  - each other step takes 2 minutes
  - → you can finish one car every 3 minutes
- Slowest stage = “bottleneck”

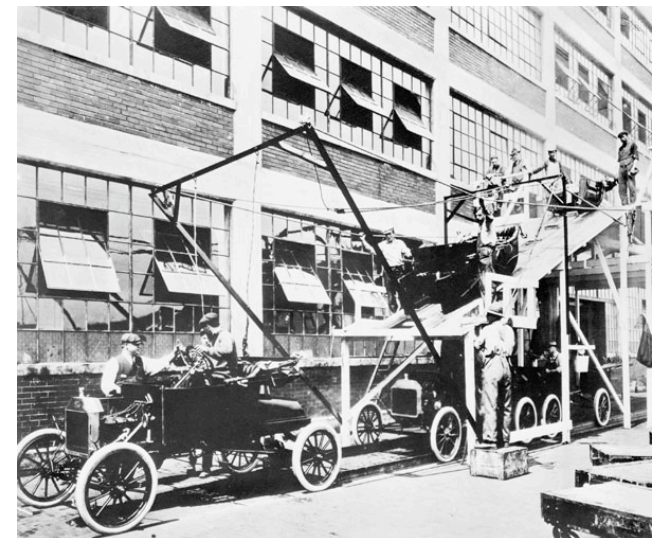

# Graphics Rendering Pipeline

- Function:
  - generate (“render”) a 2-dimensional image given 3-dimensional objects (and a virtual camera, light sources, a lighting model, etc.)
- Rendering speed
  - update speed of images
  - expressed in frames per second (fps)
  - rendering speed is determined by the bottleneck



# Overview

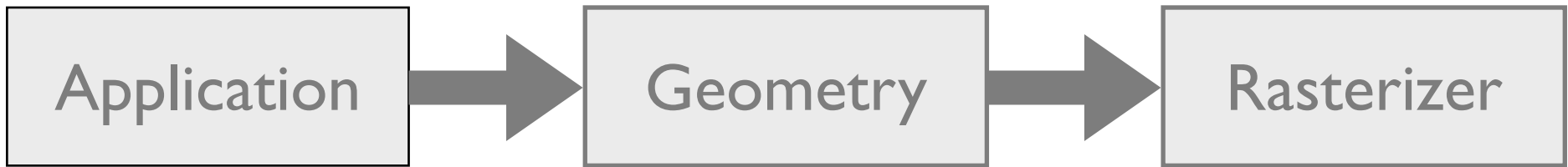

# Overview

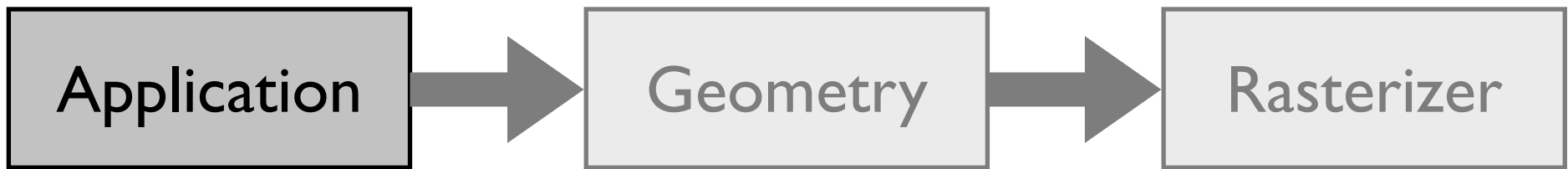

# The Application Stage

- Fully controlled by application programmer
  - collision detection,
  - input handling (keyboard, mouse, any other devices)
  - animations (updating model transformations)
  - acceleration algorithms (such as hierarchical view frustum culling)
- Output:
  - Geometry to be rendered in the form of rendering primitives (points, lines, triangles)

# Overview



# The Geometry Stage

- Computes what should be drawn, where it should be drawn, how it should be drawn.
- Handles per-vertex operations.
- Can be subdivided into five functional stages:
  - model & view transform, lighting, projection, clipping, screen mapping.
- With a single light source, each vertex requires approximately 100 individual floating point operations!

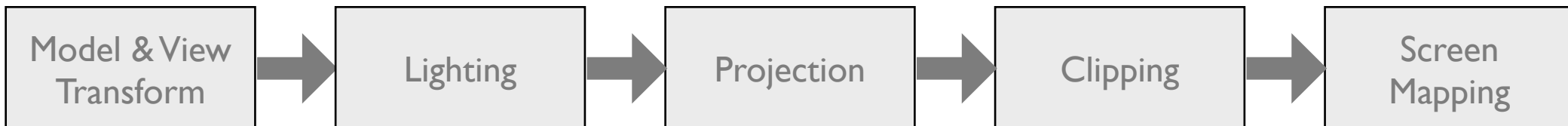

# Overview

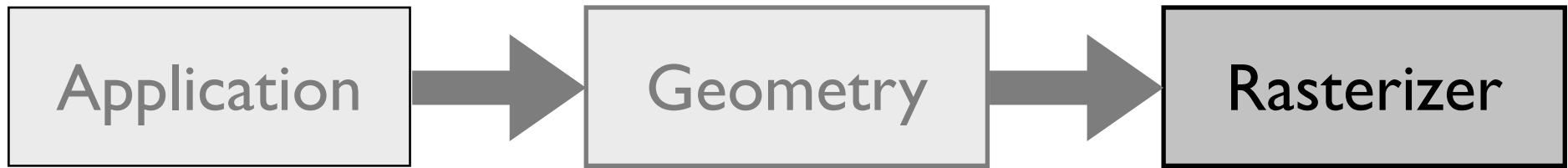

# The Rasterization Stage

- Input: transformed and projected vertices, colors, and texture coordinates from the geometry stage.
- Task is to assign correct colors to the pixels on the screen to render a correct image.
- *Rasterization* (aka *scan conversion*):
  - Conversion of 2d vertices in screen space (each with a z-value, one or two colors, and possibly a set of texture coordinates) into pixels on the screen.

# The Rasterization Stage

- Handles per-pixel operations.
- Information for each pixel is stored in the color buffer (a rectangular array of colors).
- Color buffer should contain only the colors of the primitives which are visible from the point of view of the camera.
- This is usually done using the Z-Buffer algorithm.



# Summary

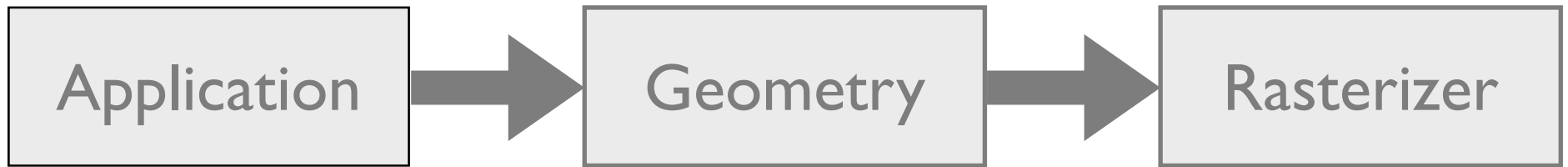

**STL?**

~~STL?~~

**SDL**

# Simple Directmedia Layer

# SDL

- SDL is a free cross-platform multi-media development API
- abstraction for OS-dependent tasks
  - create window and rendering context
  - handle keyboard, mouse, and joystick events
  - audio
  - thread abstraction
  - ...
- see <http://libsdl.org>

# anatomy of an SDL application

1. Initialise SDL (SDL\_Init())
2. Create OpenGL rendering context (SDL\_SetVideoMode())
3. Do your own OpenGL and app initialisation
4. Run main loop:
  - rendering
  - event processing
5. Cleanup

**brace yourselves**



# anatomy of an SDL application

```
int main(int argc, char ** argv)
{
    int width = 640, height = 480;

    // Initialize SDL
    if (SDL_Init(SDL_INIT_VIDEO) < 0) {
        fprintf(stderr, "Unable to init SDL: %s\n", SDL_GetError());
        return -1;
    }

    if (!SDL_SetVideoMode(width, height, 32, SDL_OPENGL)) {
        fprintf(stderr, "Unable set video mode: %s\n", SDL_GetError());
        SDL_Quit();
        return -1;
    }

    SDL_WM_SetCaption("SDL/OpenGL intro", NULL); // window title
    myinit(width, height); // initialize OpenGL

    // ... continued on next page
```

# anatomy of an SDL application

```
// main application loop
bool done = false;
while (!done) {
    mydisplay();
    SDL_Event event;
    while (SDL_PollEvent(&event)) {
        if (event.type == SDL_QUIT) done = true;
        if (event.type == SDL_KEYDOWN) {
            switch(event.key.keysym.sym) {
                case SDLK_ESCAPE:
                    done = true;
            }
        }
    }
}

SDL_Quit();
return 0;
}
```

SDL/OpenGL intro

# basicsdl.cpp

</SDL>

now for some OpenGL fun!

SDL/OpenGL intro

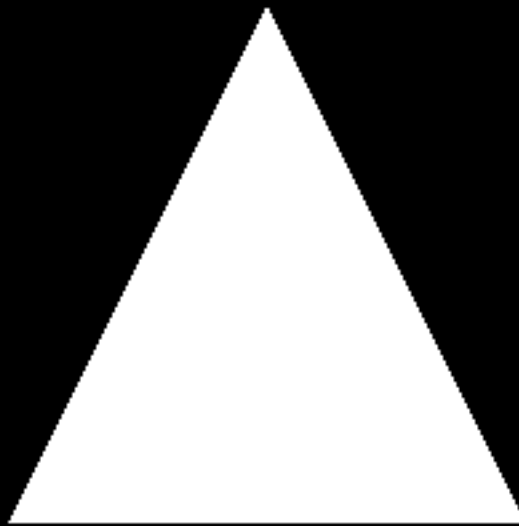

# triangle.cpp

# OpenGL initialisation

```
void myinit(int width, int height)
{
    glClearColor(0.0f, 0.0f, 0.0f, 0.0f);
    glEnable(GL_DEPTH_TEST);
    glViewport(0, 0, width, height);

    glMatrixMode(GL_PROJECTION);
    glLoadIdentity();
    gluPerspective(45.0, (float)width/(float)height, 0.1, 100.0);
    gluLookAt(0.0, 0.0, 4.0, // eye
              0.0, 0.0, -1.0, // center
              0.0, 1.0, 0.0); // up

    glMatrixMode(GL_MODELVIEW);
}
```

# drawing

```
void mydisplay()
{
    glClear(GL_COLOR_BUFFER_BIT | GL_DEPTH_BUFFER_BIT);
    glLoadIdentity();

    glBegin(GL_TRIANGLES);
    glVertex3f( 0.0f, 1.0f, 0.0f);
    glVertex3f( 1.0f,-1.0f, 0.0f);
    glVertex3f(-1.0f,-1.0f, 0.0f);
    glEnd();

    SDL_GL_SwapBuffers();
}
```



SDL/OpenGL intro

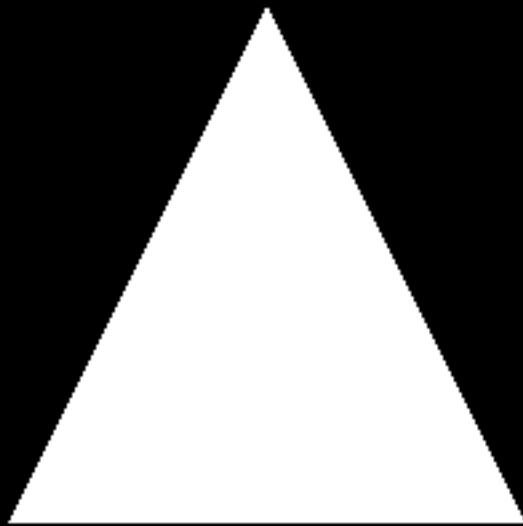

# OpenGL initialisation

```
void myinit(int width, int height)
{
    glClearColor(0.0f, 0.0f, 0.0f, 0.0f);
    glEnable(GL_DEPTH_TEST);
    glViewport(0, 0, width, height);

    glMatrixMode(GL_PROJECTION);
    glLoadIdentity();
    gluPerspective(45.0, (float)width/(float)height, 0.1, 100.0);
    gluLookAt(0.0, 0.0, 4.0, // eye
              0.0, 0.0, -1.0, // center
              0.0, 1.0, 0.0); // up

    glMatrixMode(GL_MODELVIEW);
}
```

# OpenGL initialisation

```
void myinit(int width, int height)
{
    glClearColor(0.0f, 0.0f, 0.0f, 0.0f);
    glEnable(GL_DEPTH_TEST);
    glViewport(0, 0, width, height);

    glMatrixMode(GL_PROJECTION);
    glLoadIdentity();
    gluPerspective(45.0, (float)width/(float)height, 0.1, 100.0);
    gluLookAt(0.0, 0.0, 4.0, // eye
              0.0, 0.0, -1.0, // center
              0.0, 1.0, 0.0); // up

    glMatrixMode(GL_MODELVIEW);
}
```

# OpenGL initialisation

```
void myinit(int width, int height)
{
    glClearColor(0.0f, 0.0f, 0.0f, 0.0f);
    glEnable(GL_DEPTH_TEST);
    glViewport(0, 0, width, height);

    glMatrixMode(GL_PROJECTION);
    glLoadIdentity();
    gluPerspective(45.0, (float)width/(float)height, 0.1, 100.0);
    gluLookAt(0.0, 0.0, 4.0, // eye
              0.0, 0.0, -1.0, // center
              0.0, 1.0, 0.0); // up

    glMatrixMode(GL_MODELVIEW);
}
```

# The Z-Buffer

- The Z-buffer is the same size as the color buffer and stores the z-value from the camera to the closest primitive.
- When a primitive is rendered to a certain pixel, the z-value of the primitive at that pixel is computed and compared to the contents of the Z-buffer at the same pixel.
- If the new z value is smaller than the z value in the Z-buffer, the primitive is closer to the camera → the z value and the color of that pixel are updated.
- If the new z value is greater, color and z are not changed.

# OpenGL initialisation

```
void myinit(int width, int height)
{
    glClearColor(0.0f, 0.0f, 0.0f, 0.0f);
    glEnable(GL_DEPTH_TEST);
    glViewport(0, 0, width, height);

    glMatrixMode(GL_PROJECTION);
    glLoadIdentity();
    gluPerspective(45.0, (float)width/(float)height, 0.1, 100.0);
    gluLookAt(0.0, 0.0, 4.0, // eye
              0.0, 0.0, -1.0, // center
              0.0, 1.0, 0.0); // up

    glMatrixMode(GL_MODELVIEW);
}
```

# OpenGL initialisation

```
void myinit(int width, int height)
{
    glClearColor(0.0f, 0.0f, 0.0f, 0.0f);
    glEnable(GL_DEPTH_TEST);
    glViewport(0, 0, width, height);

    glMatrixMode(GL_PROJECTION);
    glLoadIdentity();
    gluPerspective(45.0, (float)width/(float)height, 0.1, 100.0);
    gluLookAt(0.0, 0.0, 4.0, // eye
              0.0, 0.0, -1.0, // center
              0.0, 1.0, 0.0); // up

    glMatrixMode(GL_MODELVIEW);
}
```

# OpenGL initialisation

```
void myinit(int width, int height)
{
    glClearColor(0.0f, 0.0f, 0.0f, 0.0f);
    glEnable(GL_DEPTH_TEST);
    glViewport(0, 0, width, height);

    glMatrixMode(GL_PROJECTION);
    glLoadIdentity();
    gluPerspective(45.0, (float)width/(float)height, 0.1, 100.0);
    gluLookAt(0.0, 0.0, 4.0, // eye
              0.0, 0.0, -1.0, // center
              0.0, 1.0, 0.0); // up

    glMatrixMode(GL_MODELVIEW);
}
```



# OpenGL initialisation

```
void myinit(int width, int height)
{
    glClearColor(0.0f, 0.0f, 0.0f, 0.0f);
    glEnable(GL_DEPTH_TEST);
    glViewport(0, 0, width, height);

    glMatrixMode(GL_PROJECTION);
    glLoadIdentity();
    gluPerspective(45.0, (float)width/(float)height, 0.1, 100.0);
    gluLookAt(0.0, 0.0, 4.0, // eye
              0.0, 0.0, -1.0, // center
              0.0, 1.0, 0.0); // up

    glMatrixMode(GL_MODELVIEW);
}
```

# projection

- Two projection methods:
  - orthographic vs. perspective projection
- Orthographic projection:
  - View volume is a rectangular box.
  - Parallel lines remain parallel after the transform.



# projection

```
glOrtho(float left, float right,  
        float bottom, float top,  
        float near, float far);
```

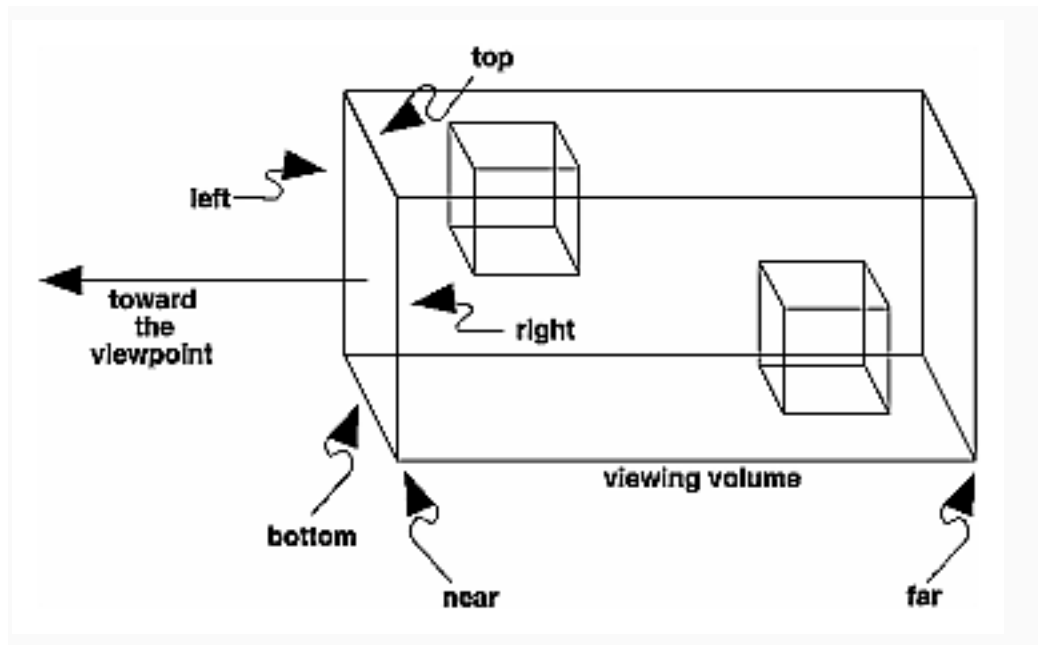

Model & View  
Transform

Lighting

Projection

Clipping

Screen  
Mapping

# projection

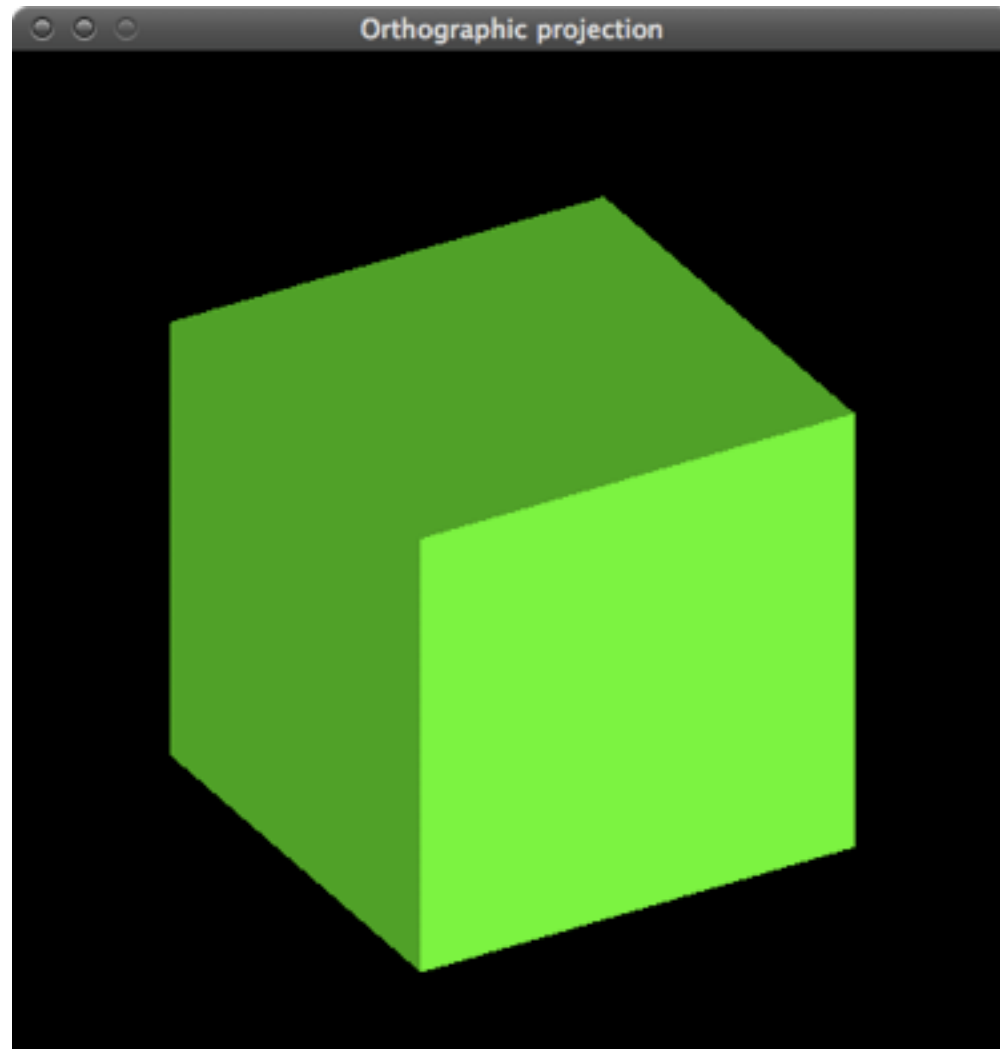

# proj\_ortho.cpp

Model & View  
Transform

Lighting

Projection

Clipping

Screen  
Mapping

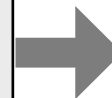

# projection

- Perspective projection:
  - The farther away an object lies from the camera, the smaller it appears after projection.
  - Parallel lines converge at the horizon.
  - View volume (called frustum) is a truncated pyramid with a rectangular base.



# projection

```
glFrustum(float left, float right,  
float bottom, float top,  
float near, float far);
```

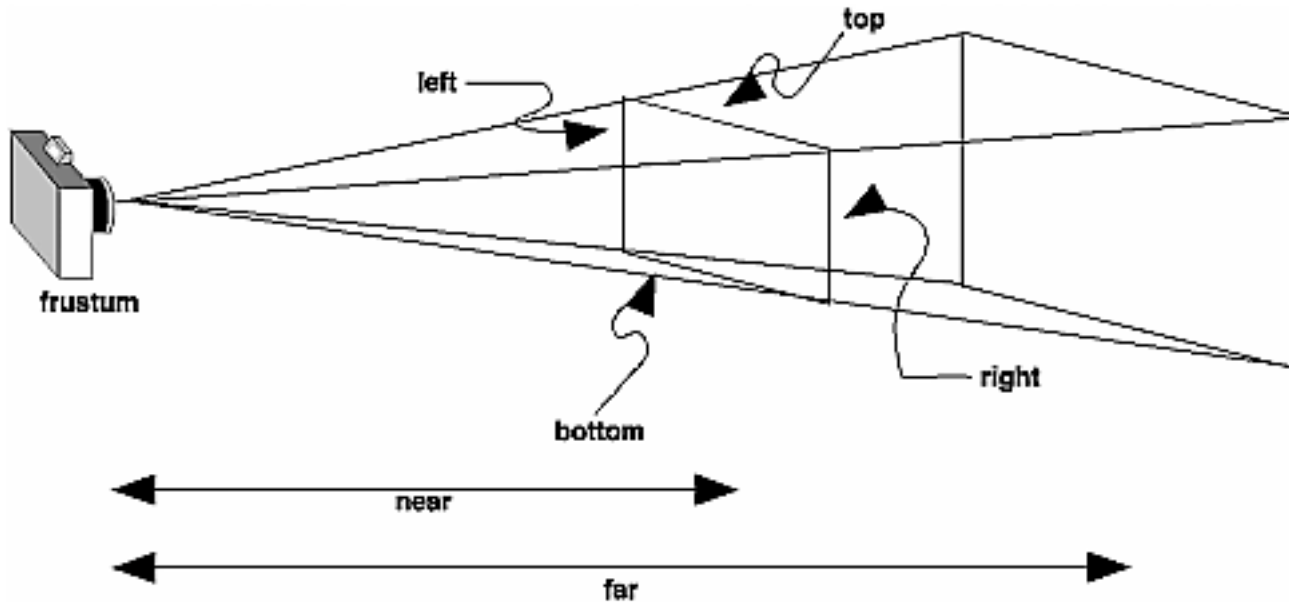

Model & View  
Transform

Lighting

Projection

Clipping

Screen  
Mapping

# projection

```
gluPerspective(float fovy, float aspect,  
              float near, float far);
```

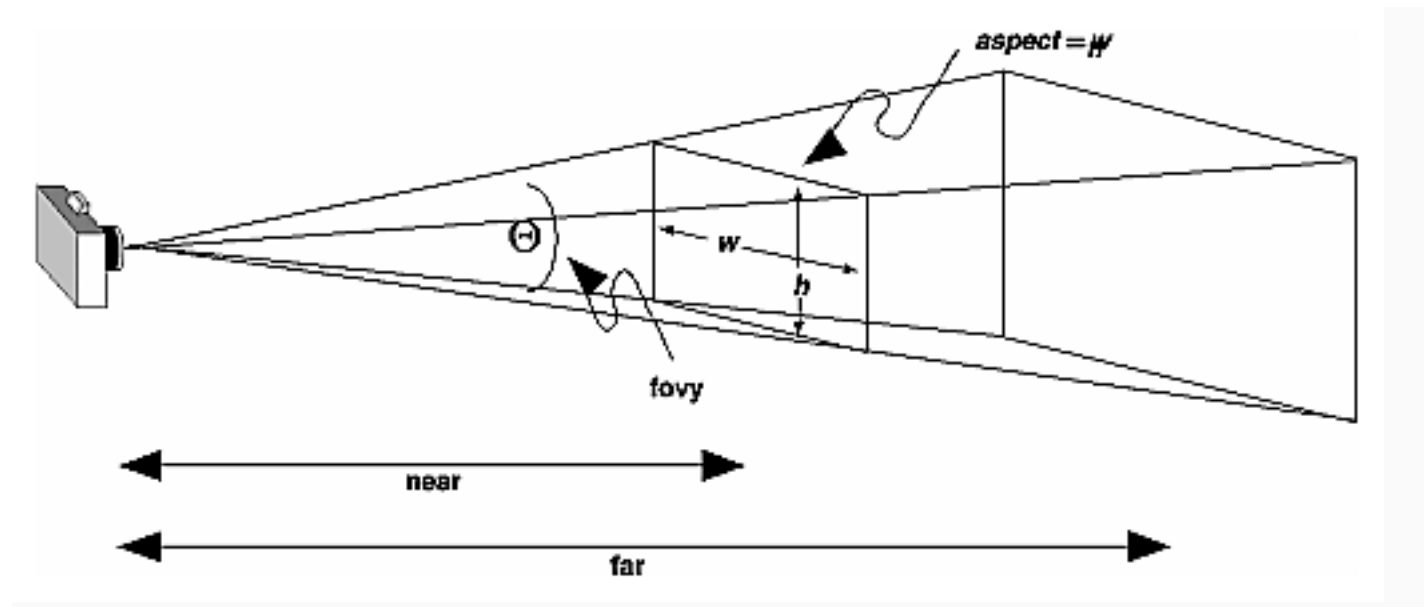

Model & View  
Transform

Lighting

Projection

Clipping

Screen  
Mapping

# projection

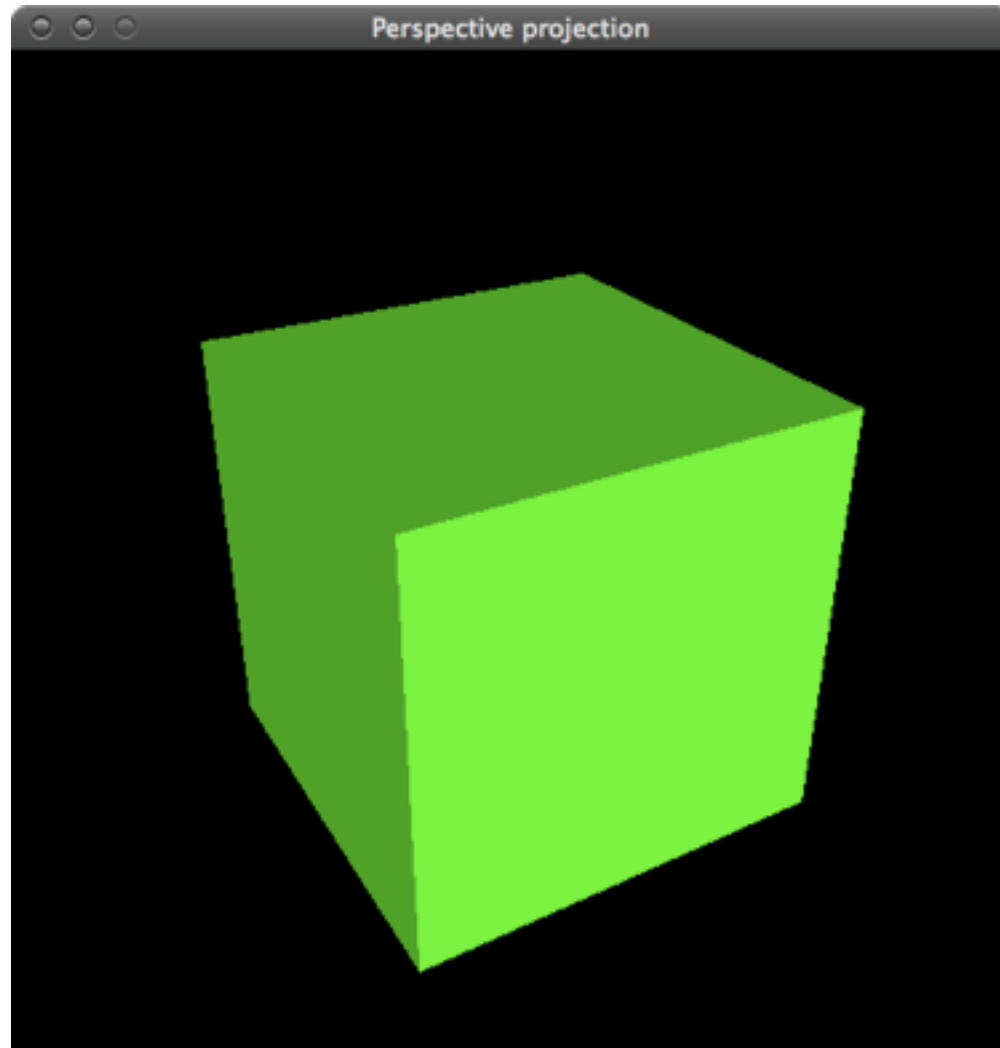

# proj\_persp.cpp

Model & View  
Transform

Lighting

Projection

Clipping

Screen  
Mapping



# OpenGL initialisation

```
void myinit(int width, int height)
{
    glClearColor(0.0f, 0.0f, 0.0f, 0.0f);
    glEnable(GL_DEPTH_TEST);
    glViewport(0, 0, width, height);

    glMatrixMode(GL_PROJECTION);
    glLoadIdentity();
    gluPerspective(45.0, (float)width/(float)height, 0.1, 100.0);
    gluLookAt(0.0, 0.0, 4.0, // eye
              0.0, 0.0, -1.0, // center
              0.0, 1.0, 0.0); // up

    glMatrixMode(GL_MODELVIEW);
}
```

# OpenGL initialisation

```
void myinit(int width, int height)
{
    glClearColor(0.0f, 0.0f, 0.0f, 0.0f);
    glEnable(GL_DEPTH_TEST);
    glViewport(0, 0, width, height);

    glMatrixMode(GL_PROJECTION);
    glLoadIdentity();
    glOrtho(-3, 3, -3, 3, 2, 10);
    gluLookAt(0.0, 0.0, 8.0, // eye
              0.0, 0.0, -1.0, // center
              0.0, 1.0, 0.0); // up

    glMatrixMode(GL_MODELVIEW);
}
```

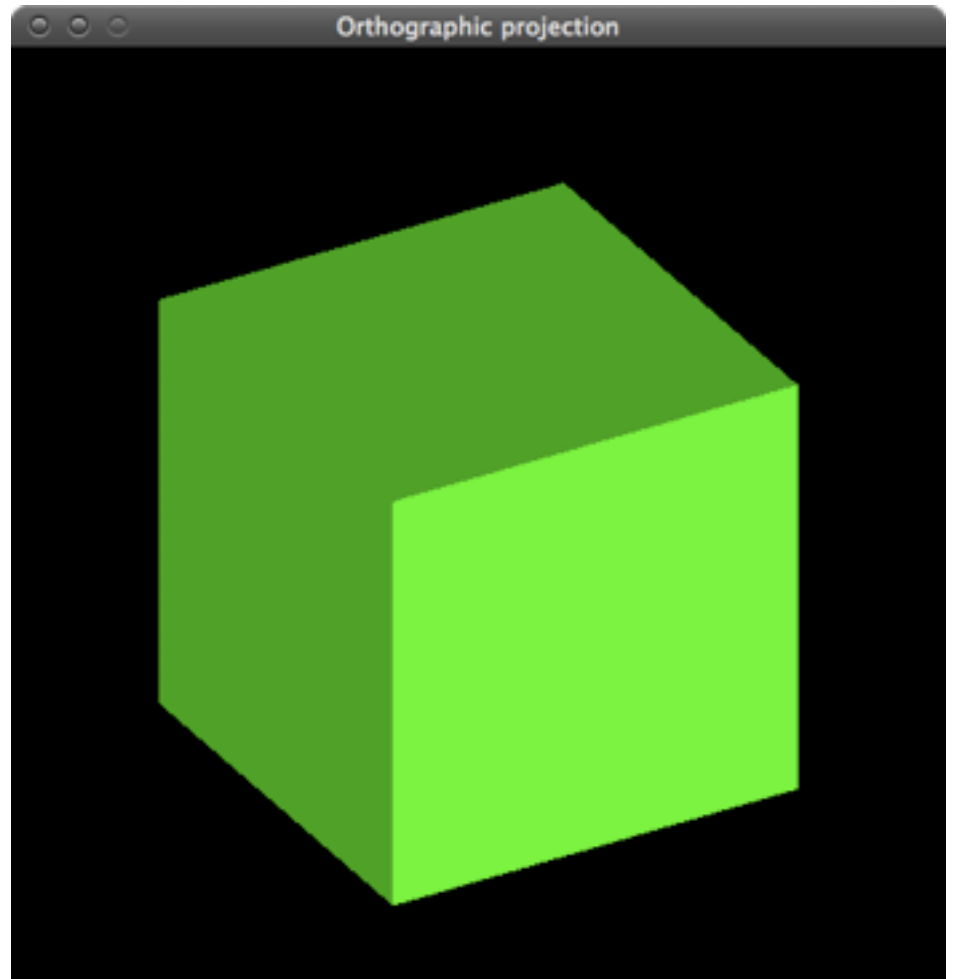
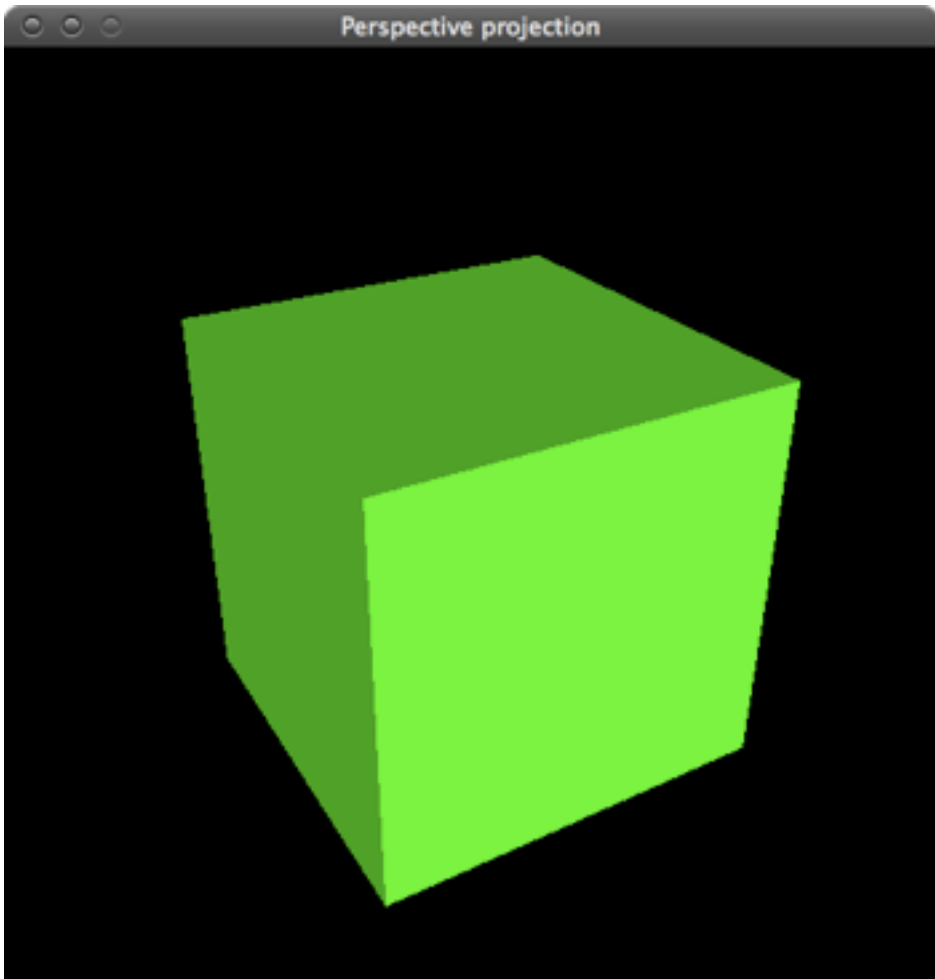

World-space view

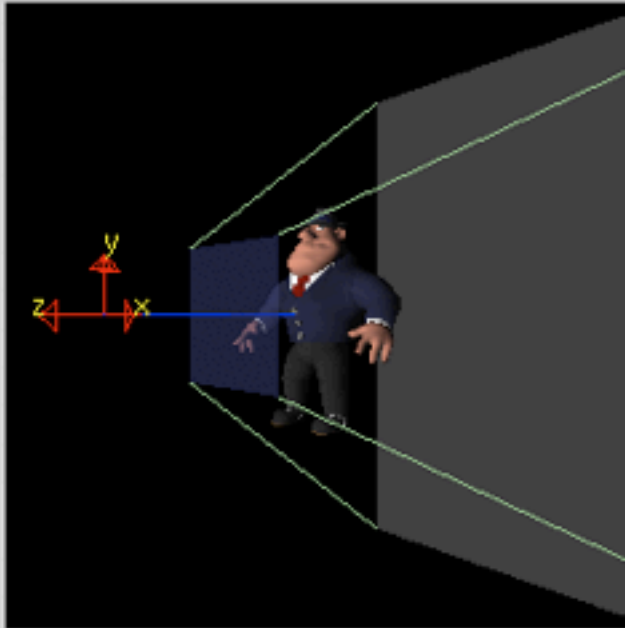

Screen-space view



Command manipulation window

```
gluPerspective( fovy aspect zNear zFar  
gluLookAt( 60.0 , 1.00 , 1.0 , 10.0 );  
           0.00 , 0.00 , 2.00 , ← eye  
           0.00 , 0.00 , 0.00 , ← center  
           0.00 , 1.00 , 0.00 ); ← up
```

**Click on the arguments and move the mouse to modify values.**

# OpenGL initialisation

```
void myinit(int width, int height)
{
    glClearColor(0.0f, 0.0f, 0.0f, 0.0f);
    glEnable(GL_DEPTH_TEST);
    glViewport(0, 0, width, height);

    glMatrixMode(GL_PROJECTION);
    glLoadIdentity();
    gluPerspective(45.0, (float)width/(float)height, 0.1, 100.0);
    gluLookAt(0.0, 0.0, 4.0, // eye
              0.0, 0.0, -1.0, // center
              0.0, 1.0, 0.0); // up

    glMatrixMode(GL_MODELVIEW);
}
```

# OpenGL initialisation

```
void myinit(int width, int height)
{
    glClearColor(0.0f, 0.0f, 0.0f, 0.0f);
    glEnable(GL_DEPTH_TEST);
    glViewport(0, 0, width, height);

    glMatrixMode(GL_PROJECTION);
    glLoadIdentity();
    gluPerspective(45.0, (float)width/(float)height, 0.1, 100.0);
    gluLookAt(0.0, 0.0, 4.0, // eye
              0.0, 0.0, -1.0, // center
              0.0, 1.0, 0.0); // up

    glMatrixMode(GL_MODELVIEW);
}
```

# drawing

```
void mydisplay()  
{  
    glClear(GL_COLOR_BUFFER_BIT | GL_DEPTH_BUFFER_BIT);  
    glLoadIdentity();  
  
    glBegin(GL_TRIANGLES);  
    glVertex3f( 0.0f, 1.0f, 0.0f);  
    glVertex3f( 1.0f,-1.0f, 0.0f);  
    glVertex3f(-1.0f,-1.0f, 0.0f);  
    glEnd();  
  
    SDL_GL_SwapBuffers();  
}
```

# drawing

```
void mydisplay()  
{  
    glClear(GL_COLOR_BUFFER_BIT | GL_DEPTH_BUFFER_BIT);  
    glLoadIdentity();  
  
    glBegin(GL_TRIANGLES);  
    glVertex3f( 0.0f, 1.0f, 0.0f);  
    glVertex3f( 1.0f,-1.0f, 0.0f);  
    glVertex3f(-1.0f,-1.0f, 0.0f);  
    glEnd();  
  
    SDL_GL_SwapBuffers();  
}
```



# drawing

```
void mydisplay()  
{  
    glClear(GL_COLOR_BUFFER_BIT | GL_DEPTH_BUFFER_BIT);  
    glLoadIdentity();  
  
    glBegin(GL_TRIANGLES);  
    glVertex3f( 0.0f, 1.0f, 0.0f);  
    glVertex3f( 1.0f,-1.0f, 0.0f);  
    glVertex3f(-1.0f,-1.0f, 0.0f);  
    glEnd();  
  
    SDL_GL_SwapBuffers();  
}
```

# drawing

```
void mydisplay()  
{  
    glClear(GL_COLOR_BUFFER_BIT | GL_DEPTH_BUFFER_BIT);  
    glLoadIdentity();  
  
    glBegin(GL_TRIANGLES);  
    glVertex3f( 0.0f, 1.0f, 0.0f);  
    glVertex3f( 1.0f,-1.0f, 0.0f);  
    glVertex3f(-1.0f,-1.0f, 0.0f);  
    glEnd();  
  
    SDL_GL_SwapBuffers();  
}
```

# drawing

```
void mydisplay()  
{  
    glClear(GL_COLOR_BUFFER_BIT | GL_DEPTH_BUFFER_BIT);  
    glLoadIdentity();  
  
    glBegin(GL_TRIANGLES);  
    glVertex3f( 0.0f, 1.0f, 0.0f);  
    glVertex3f( 1.0f,-1.0f, 0.0f);  
    glVertex3f(-1.0f,-1.0f, 0.0f);  
    glEnd();  
  
    SDL_GL_SwapBuffers();  
}
```

# drawing

```
void mydisplay()  
{  
    glClear(GL_COLOR_BUFFER_BIT | GL_DEPTH_BUFFER_BIT);  
    glLoadIdentity();  
  
    glBegin(GL_TRIANGLES);  
    glVertex3f( 0.0f, 1.0f, 0.0f);  
    glVertex3f( 1.0f,-1.0f, 0.0f);  
    glVertex3f(-1.0f,-1.0f, 0.0f);  
    glEnd();  
  
    SDL_GL_SwapBuffers();  
}
```

Screen-space view

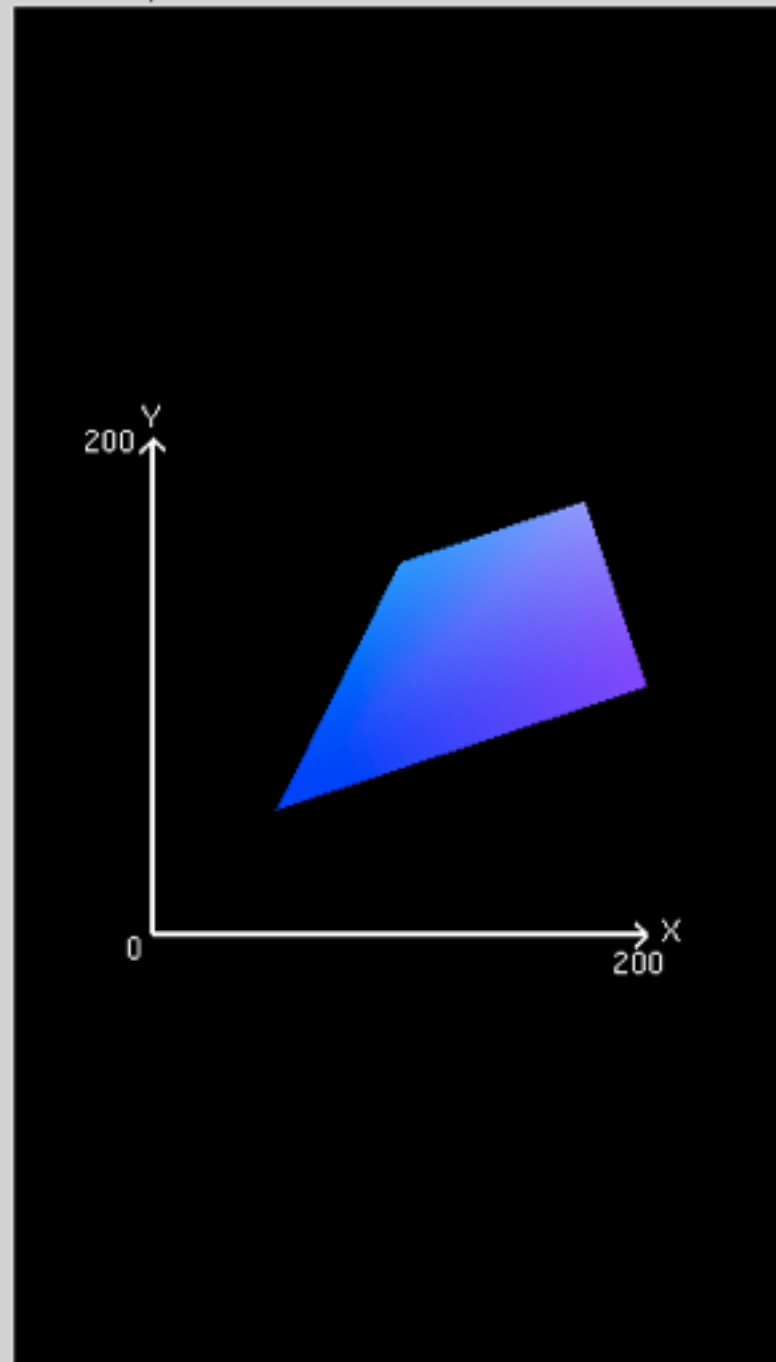

Command manipulation window

```
glBegin (GL_TRIANGLE_FAN);  
glColor3f (0.00 , 0.00 , 1.00 );  
glVertex2f (50.0 , 50.0 );  
glColor3f (0.00 , 0.50 , 1.00 );  
glVertex2f (100.0 , 150.0 );  
glColor3f (0.50 , 0.50 , 1.00 );  
glVertex2f (175.0 , 175.0 );  
glColor3f (0.50 , 0.00 , 1.00 );  
glVertex2f (200.0 , 100.0 );  
glEnd();
```

**Click on the arguments and  
move the mouse to modify values.**

# drawing

```
void mydisplay()  
{  
    glClear(GL_COLOR_BUFFER_BIT | GL_DEPTH_BUFFER_BIT);  
    glLoadIdentity();  
  
    glBegin(GL_TRIANGLES);  
    glVertex3f( 0.0f, 1.0f, 0.0f);  
    glVertex3f( 1.0f,-1.0f, 0.0f);  
    glVertex3f(-1.0f,-1.0f, 0.0f);  
    glEnd();  
  
    SDL_GL_SwapBuffers();  
}
```

# drawing

```
void mydisplay()
{
    glClear(GL_COLOR_BUFFER_BIT | GL_DEPTH_BUFFER_BIT);
    glLoadIdentity();

    glBegin(GL_TRIANGLES);
    glVertex3f( 0.0f, 1.0f, 0.0f);
    glVertex3f( 1.0f,-1.0f, 0.0f);
    glVertex3f(-1.0f,-1.0f, 0.0f);
    glEnd();

    SDL_GL_SwapBuffers();
}
```

# Double-Buffering

- To avoid visible flickering during the rasterization process, double buffering is used:
  - Rendering is done off-screen in the back buffer.
  - When the rendered scene is complete, front and back buffer are swapped.
  - The swapping is done during the vertical monitor sync, so that it is not visible.



let's move the triangle

SDL/OpenGL intro

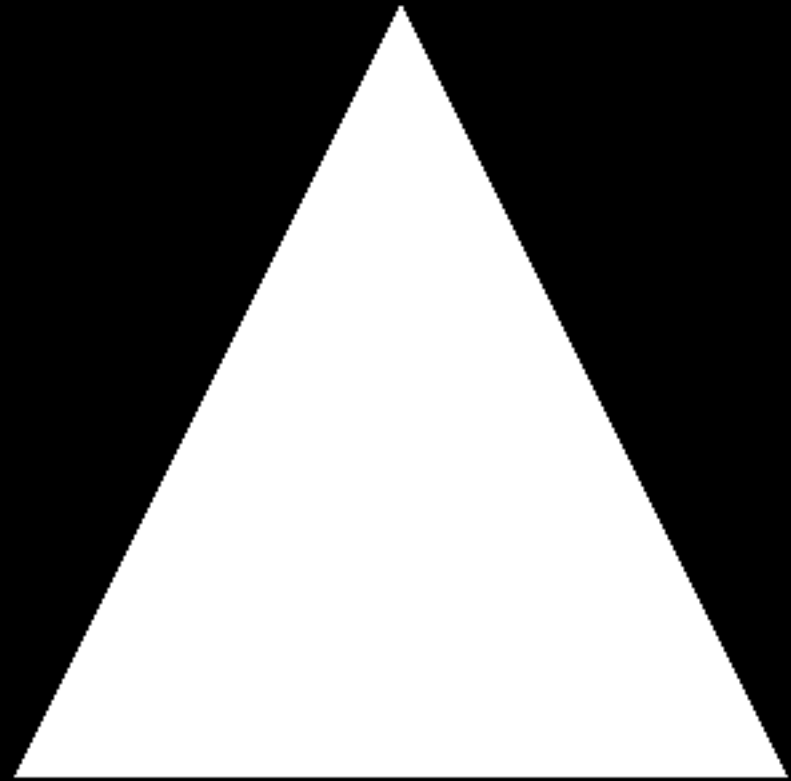

# modify drawing code

```
void mydisplay()  
{  
    glClear(GL_COLOR_BUFFER_BIT | GL_DEPTH_BUFFER_BIT);  
    glLoadIdentity();  
  
    glBegin(GL_TRIANGLES);  
    glVertex3f( 0.0f, 1.0f, 0.0f);  
    glVertex3f( 1.0f,-1.0f, 0.0f);  
    glVertex3f(-1.0f,-1.0f, 0.0f);  
    glEnd();  
  
    SDL_GL_SwapBuffers();  
}
```

# modified drawing code

```
void mydisplay()
{
    glClear(GL_COLOR_BUFFER_BIT | GL_DEPTH_BUFFER_BIT);
    glLoadIdentity();

    glBegin(GL_TRIANGLES);
    glVertex3f( 1.0f, 1.0f, 0.0f);
    glVertex3f( 2.0f,-1.0f, 0.0f);
    glVertex3f( 0.0f,-1.0f, 0.0f);
    glEnd();

    SDL_GL_SwapBuffers();
}
```

**this works**

but can get kinda tedious

**there's a better way**

# original drawing code

```
void mydisplay()
{
    glClear(GL_COLOR_BUFFER_BIT | GL_DEPTH_BUFFER_BIT);
    glLoadIdentity();

    glBegin(GL_TRIANGLES);
    glVertex3f( 0.0f, 1.0f, 0.0f);
    glVertex3f( 1.0f,-1.0f, 0.0f);
    glVertex3f(-1.0f,-1.0f, 0.0f);
    glEnd();

    SDL_GL_SwapBuffers();
}
```



# add a translation

```
void mydisplay()
{
    glClear(GL_COLOR_BUFFER_BIT | GL_DEPTH_BUFFER_BIT);
    glLoadIdentity();

    glTranslatef(1.0f, 0.0f, 0.0f);

    glBegin(GL_TRIANGLES);
    glVertex3f( 0.0f, 1.0f, 0.0f);
    glVertex3f( 1.0f,-1.0f, 0.0f);
    glVertex3f(-1.0f,-1.0f, 0.0f);
    glEnd();

    SDL_GL_SwapBuffers();
}
```

# transtri2.cpp

**and one more possibility**

# move the camera

```
void myinit(int width, int height)
{
    glClearColor(0.0f, 0.0f, 0.0f, 0.0f);
    glEnable(GL_DEPTH_TEST);
    glViewport(0, 0, width, height);
    glMatrixMode(GL_PROJECTION);
    glLoadIdentity();
    gluPerspective(45.0, (float)width/(float)height, 0.1, 100.0);
    gluLookAt(0.0, 0.0, 4.0, // eye
              0.0, 0.0, -1.0, // center
              0.0, 1.0, 0.0); // up
    glMatrixMode(GL_MODELVIEW);
}
```

# move the camera

```
void myinit(int width, int height)
{
    glClearColor(0.0f, 0.0f, 0.0f, 0.0f);
    glEnable(GL_DEPTH_TEST);
    glViewport(0, 0, width, height);
    glMatrixMode(GL_PROJECTION);
    glLoadIdentity();
    gluPerspective(45.0, (float)width/(float)height, 0.1, 100.0);
    gluLookAt(-1.0, 0.0, 4.0, // eye
              -1.0, 0.0, -1.0, // center
              0.0, 1.0, 0.0); // up
    glMatrixMode(GL_MODELVIEW);
}
```

a few words on  
coordinate systems

# coordinate systems

- On the way to the screen, a model is transformed into several different spaces or coordinate systems:
  - model space
  - world space [result of model transform]
  - camera space [result of view transform]
- Model transform and view transform are often concatenated for efficiency reasons.

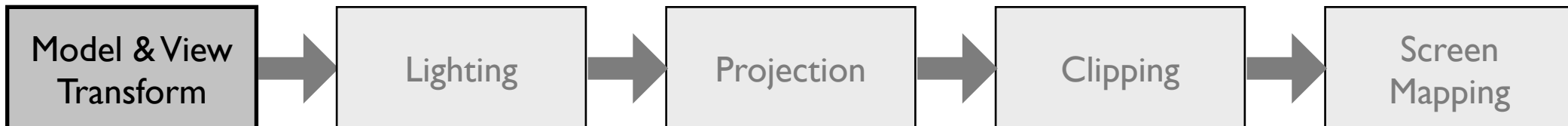

# coordinate systems

- Model space (aka object space)
  - Being in model space means that a model has not been transformed at all.
  - A model can be associated with a *model transform* to position and orient it.
  - Several model transforms associated with one model allow for multiple instances without geometry replication.

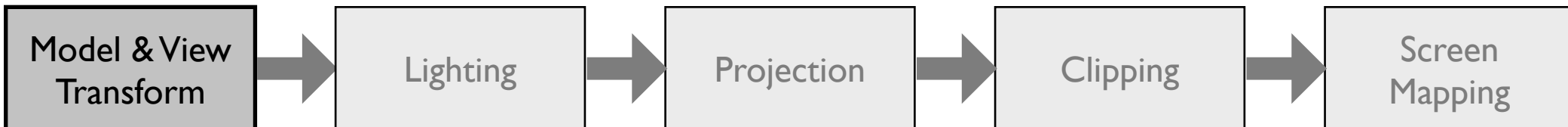

# coordinate systems

- World space
  - After the model transform has been applied to the model, it is located in world space.
  - Model transform changes vertices and normals of the model.
  - World space is unique: After the models have been transformed by their respective model transforms, all models exist in this same space.

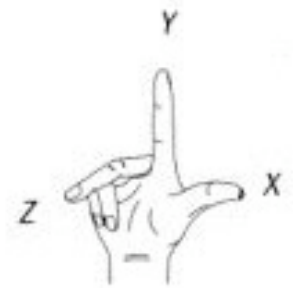

right-hand coordinate system

Model & View  
Transform

Lighting

Projection

Clipping

Screen  
Mapping



# coordinate systems

- Camera space
  - Virtual camera has a location in world space and a direction.
  - The *view transform* places the camera at the origin and aims it to look in the direction of the negative z-axis, with the y-axis pointing upwards and the x-axis pointing right.
  - All models are transformed with the view transform to facilitate projection and clipping.

Model & View  
Transform

Lighting

Projection

Clipping

Screen  
Mapping

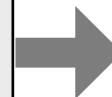

let's colour the triangle

# drawing

```
void mydisplay()
{
    glClear(GL_COLOR_BUFFER_BIT | GL_DEPTH_BUFFER_BIT);
    glLoadIdentity();

    glBegin(GL_TRIANGLES);
    glColor3f(1.0f, 0.0f, 0.0f);
    glVertex3f( 0.0f, 1.0f, 0.0f);
    glVertex3f( 1.0f,-1.0f, 0.0f);
    glVertex3f(-1.0f,-1.0f, 0.0f);
    glEnd();

    SDL_GL_SwapBuffers();
}
```

SDL/OpenGL intro

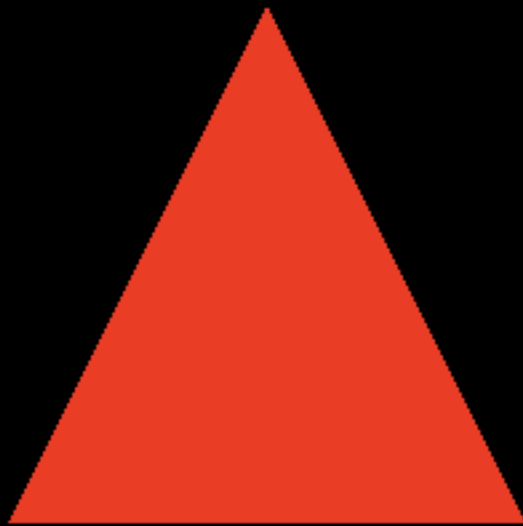

# drawing

```
void mydisplay()  
{  
    glClear(GL_COLOR_BUFFER_BIT | GL_DEPTH_BUFFER_BIT);  
    glLoadIdentity();  
  
    glBegin(GL_TRIANGLES);  
  
    glColor3f(1.0f, 0.0f, 0.0f);  
    glVertex3f( 0.0f, 1.0f, 0.0f);  
    glColor3f(0.0f, 0.0f, 1.0f);  
    glVertex3f( 1.0f,-1.0f, 0.0f);  
    glColor3f(0.0f, 1.0f, 0.0f);  
    glVertex3f(-1.0f,-1.0f, 0.0f);  
  
    glEnd();  
  
    SDL_GL_SwapBuffers();  
}
```

# tricolor.cpp

SDL/OpenGL intro

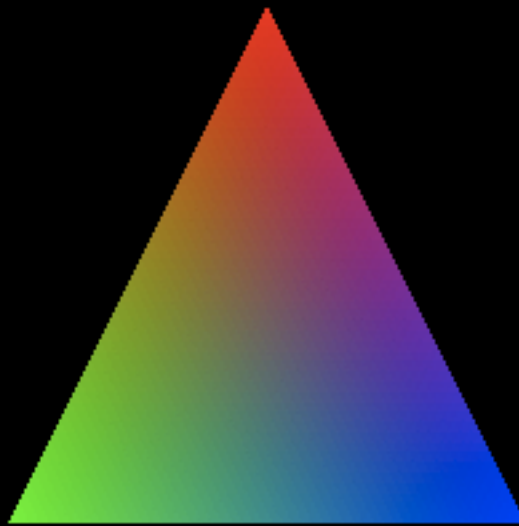

```
# tricolor.cpp
```

so let's do some 3D drawing

SDL/OpenGL intro

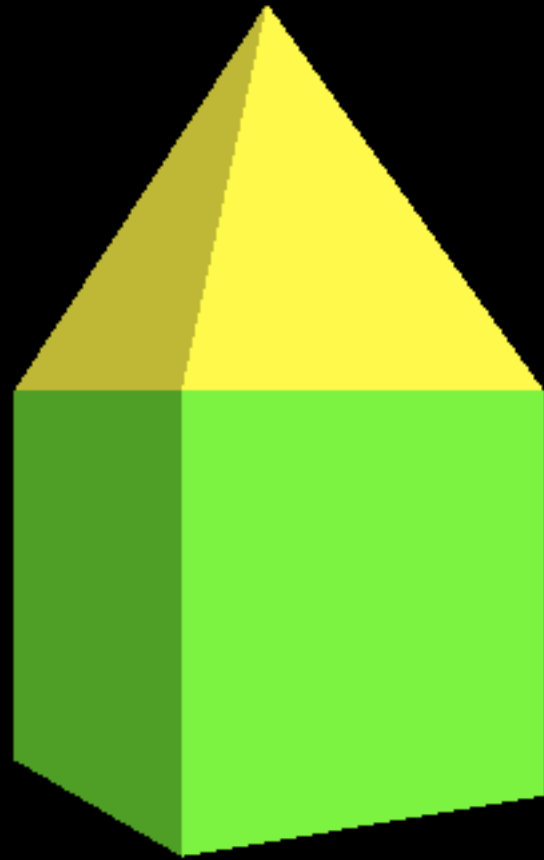



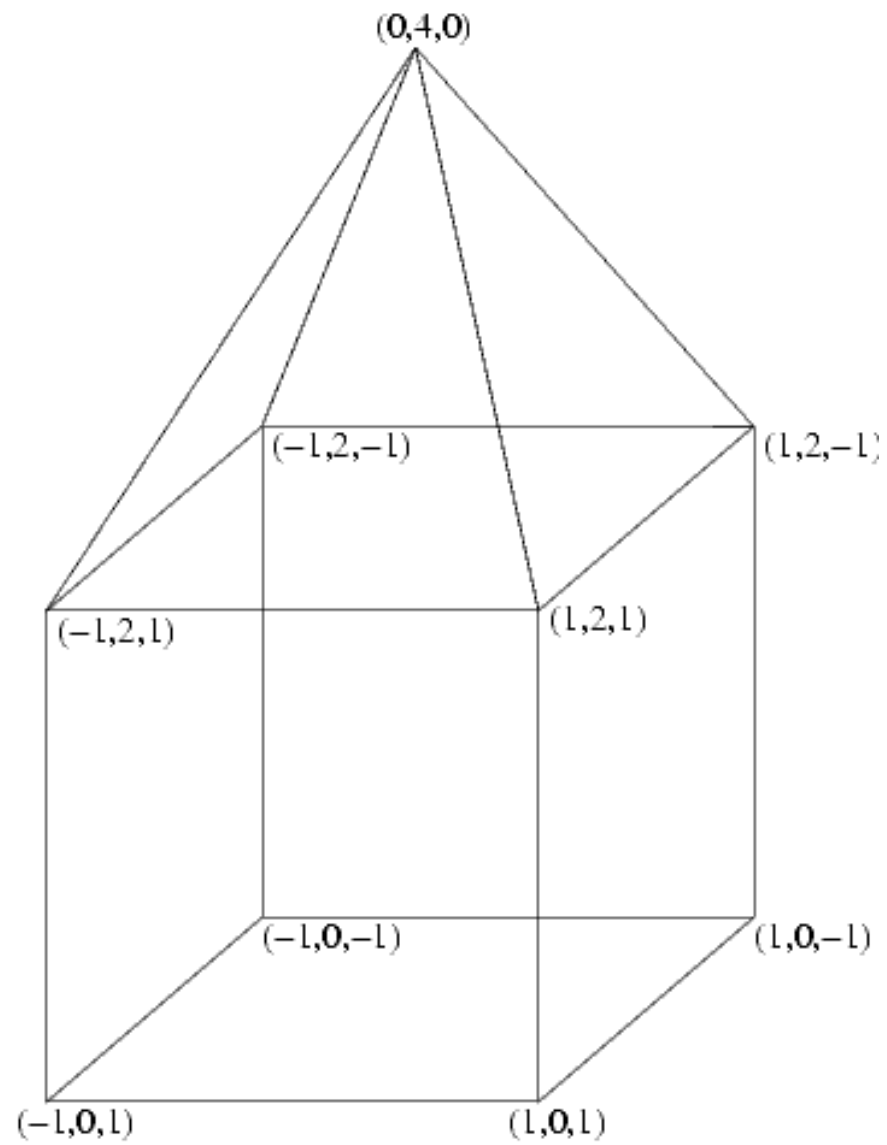

**start with framework  
from last example**

[1] SDL/OpenGL intro

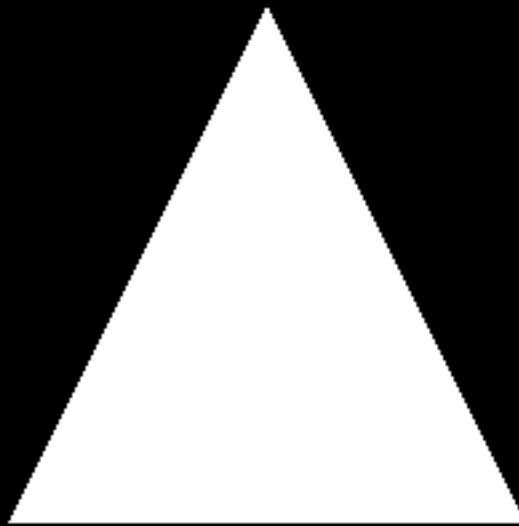

# drawing the first quad

```
void mydisplay()
{
    glClear(GL_COLOR_BUFFER_BIT | GL_DEPTH_BUFFER_BIT);
    glLoadIdentity();

    glBegin(GL_TRIANGLES);
    glVertex3f( 0.0f, 1.0f, 0.0f);
    glVertex3f( 1.0f,-1.0f, 0.0f);
    glVertex3f(-1.0f,-1.0f, 0.0f);
    glEnd();

    SDL_GL_SwapBuffers();
}
```

# drawing the first quad

```
void mydisplay()  
{  
    glClear(GL_COLOR_BUFFER_BIT | GL_DEPTH_BUFFER_BIT);  
    glLoadIdentity();  
  
    SDL_GL_SwapBuffers();  
}
```

# drawing the first quad

```
void mydisplay()
{
    glClear(GL_COLOR_BUFFER_BIT | GL_DEPTH_BUFFER_BIT);
    glLoadIdentity();

    glBegin(GL_QUADS);
    // front
    glColor3f(0, 1, 0);
    glVertex3f(-1, 0, 1);
    glVertex3f(-1, 2, 1);
    glVertex3f(1, 2, 1);
    glVertex3f(1, 0, 1);
    glEnd();

    SDL_GL_SwapBuffers();
}
```

**compile and run**

# drawing the first quad

```
void myinit(int width, int height)
{
    glClearColor(0.0f, 0.0f, 0.0f, 0.0f);
    glViewport(0, 0, width, height);
    glMatrixMode(GL_PROJECTION);
    glLoadIdentity();
    gluPerspective(45.0, (float)width/(float)height, 0.1, 100.0);
    gluLookAt(0.0, 2.0, 8.0, // eye
              0.0, 2.0, -1.0, // center
              0.0, 1.0, 0.0); // up
    glMatrixMode(GL_MODELVIEW);
}
```



SDL/OpenGL intro

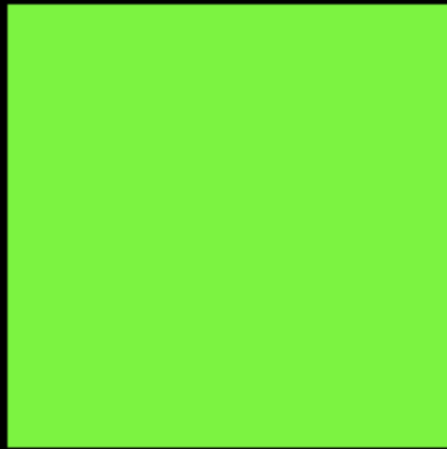

drawing the remaining quads  
is trivial and left as an exercise  
to the student

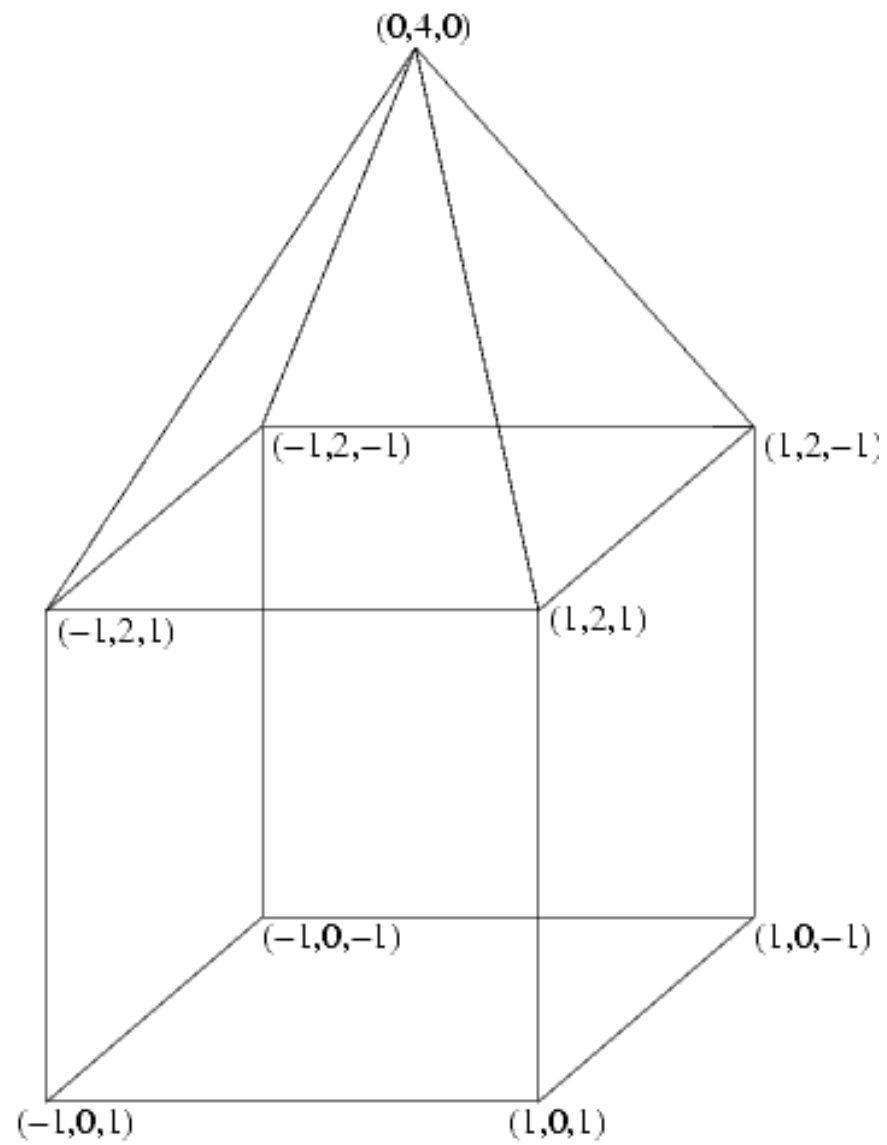

# drawing the other quads

```
// back
glVertex3f(-1, 0, -1);
glVertex3f( 1, 0, -1);
glVertex3f( 1, 2, -1);
glVertex3f(-1, 2, -1);
```

```
// left
glVertex3f(-1, 0,  1);
glVertex3f(-1, 2,  1);
glVertex3f(-1, 2, -1);
glVertex3f(-1, 0, -1);
```

```
// right
glVertex3f(1, 0,  1);
glVertex3f(1, 0, -1);
glVertex3f(1, 2, -1);
glVertex3f(1, 2,  1);
```

not much different, I'm afraid

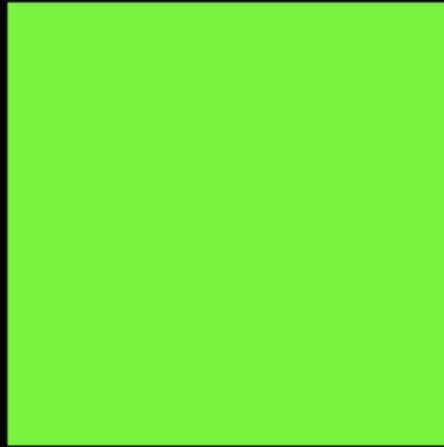

**just a question of perspective**

# rotating the scene

```
void mydisplay()
{
    glClear(GL_COLOR_BUFFER_BIT | GL_DEPTH_BUFFER_BIT);
    glLoadIdentity();

    glRotatef(rotation, 0, 1, 0);

    glBegin(GL_QUADS);
    // front
    glColor3f(0, 1, 0);
    glVertex3f(-1, 0, 1);
    glVertex3f(-1, 2, 1);
    glVertex3f(1, 2, 1);
    glVertex3f(1, 0, 1);
    glEnd();

    SDL_GL_SwapBuffers();
}
```





SDL/OpenGL intro

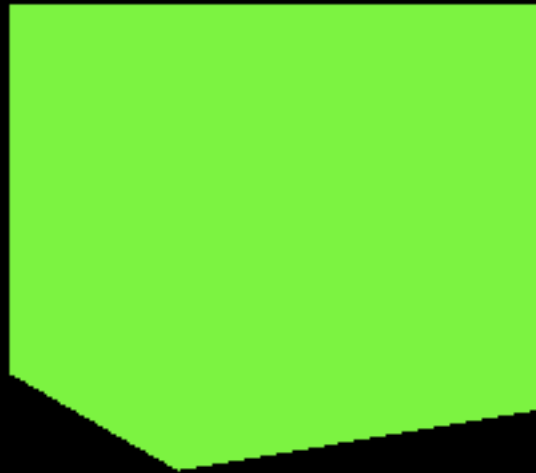

now for the pyramid...

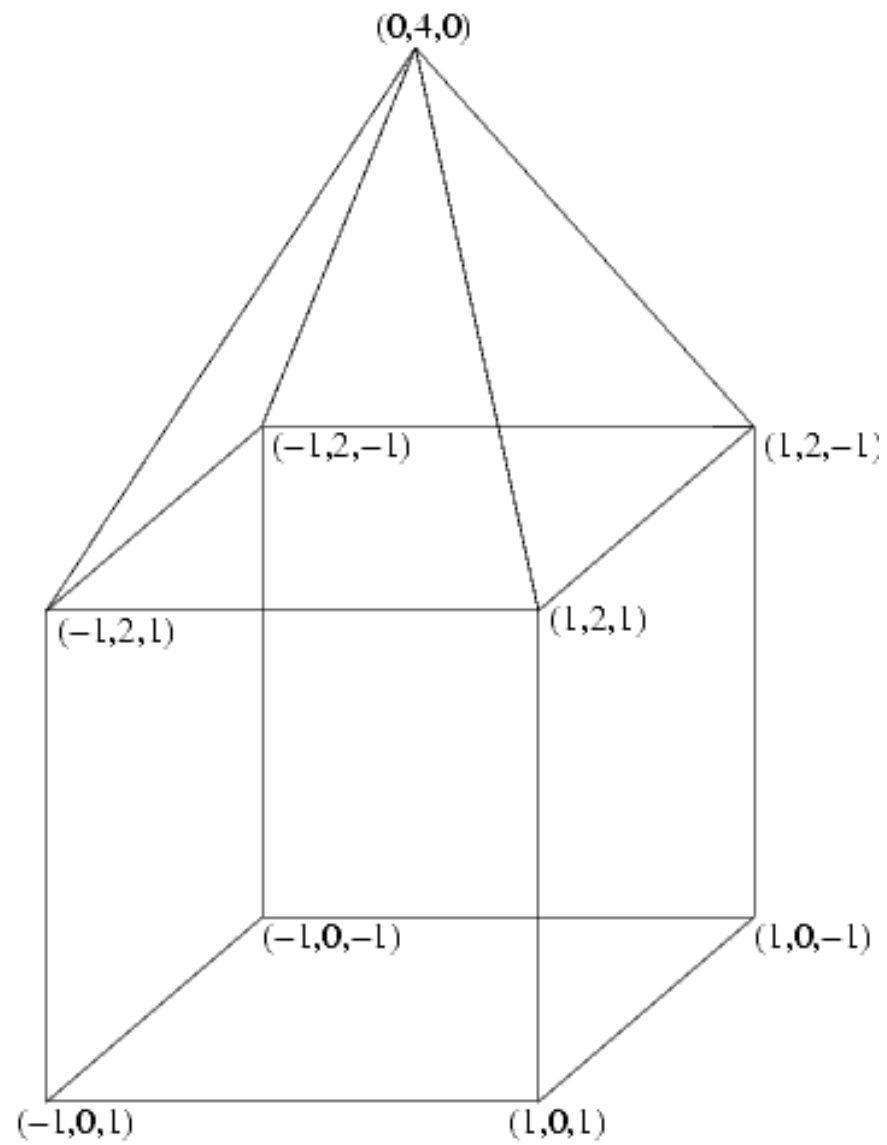

# drawing the pyramid

```
glBegin(GL_TRIANGLES);

    // front
    glColor3f(1, 1, 0);
    glVertex3f(-1, 2, 1);
    glVertex3f( 0, 4, 0);
    glVertex3f( 1, 2, 1);

    // right
    glVertex3f(1, 2, 1);
    glVertex3f(1, 2, -1);
    glVertex3f(0, 4, 0);

    // back
    glVertex3f( 1, 2, -1);
    glVertex3f(-1, 2, -1);
    glVertex3f( 0, 4, 0);

    // left
    glVertex3f(-1, 2, 1);
    glVertex3f( 0, 4, 0);
    glVertex3f(-1, 2, -1);

glEnd();
```

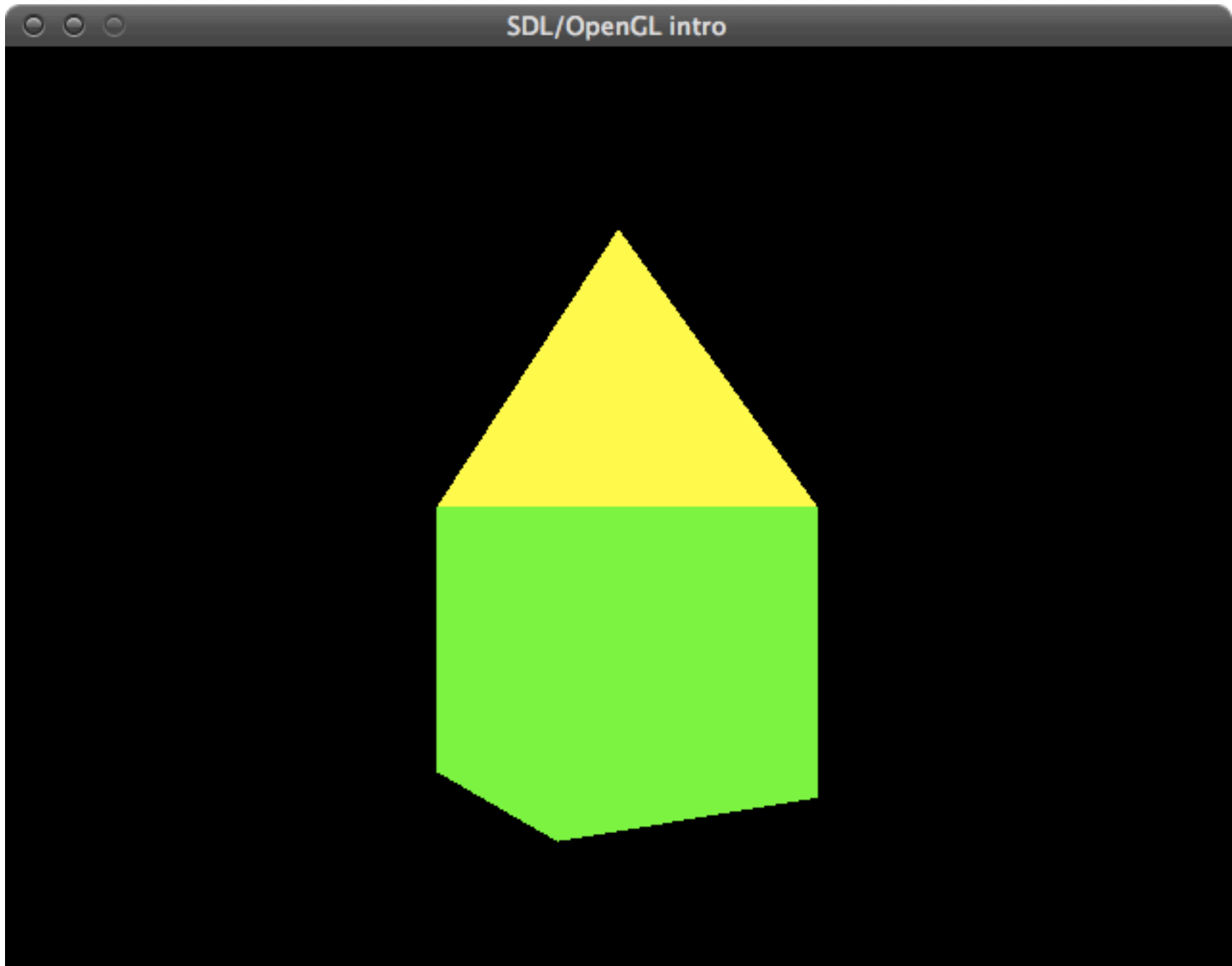

# 3ddrawing.cpp

a few words on  
**3D transformations**

# transformations overview

- OpenGL uses 4x4 matrices for modeling transformations.
  - Why not 3x3?
  - You don't want to know... (But I will tell you anyway.)
- Convenience functions for many operations:
  - `glRotate*()`, `glTranslate*()`, `glScale*()`
- Effects of transformations can be localized
  - `glPushMatrix()`, `glPopMatrix()`

# manipulating the matrix stack

- **glPushMatrix()**
  - push all matrices in the current stack (determined by `glMatrixMode()`) down one level (the topmost matrix is duplicated)
- **glPopMatrix()**
  - pop the top matrix off the stack. The second matrix from the top of the stack becomes top, the contents of the popped matrix are destroyed.



# OpenGL modelview matrix

- 4x4 matrix
- OpenGL uses column vectors instead of row vectors
- Matrices in OpenGL are defined like this:

$$M = \begin{bmatrix} m_0 & m_4 & m_8 & m_{12} \\ m_1 & m_5 & m_9 & m_{13} \\ m_2 & m_6 & m_{10} & m_{14} \\ m_3 & m_7 & m_{11} & m_{15} \end{bmatrix}$$

# model transformations in OpenGL

- 3 modeling transformations
  - `glTranslate*()`
  - `glRotate*()`
  - `glScale*()`
- Multiply a proper matrix for transform/rotate/scale to the current matrix and load the resulting matrix as current matrix.

**maths alert**

## `glScalef(a, b, c)`

- $x_1 = ax_0; y_1 = by_0; z_1 = cz_0$
- How can we write this in matrix form?

$$\begin{bmatrix} x_1 \\ y_1 \\ z_1 \end{bmatrix} = \begin{bmatrix} a & 0 & 0 \\ 0 & b & 0 \\ 0 & 0 & c \end{bmatrix} \cdot \begin{bmatrix} x_0 \\ y_0 \\ z_0 \end{bmatrix} = \begin{bmatrix} ax_0 \\ by_0 \\ cz_0 \end{bmatrix}$$

- Thus the scaling matrix is

$$S = \begin{bmatrix} a & 0 & 0 \\ 0 & b & 0 \\ 0 & 0 & c \end{bmatrix}$$

## `glRotatef(a, x, y, z)`

- Similarly for rotation we have:

- `glRotatef(a, 1, 0, 0):`

$$\begin{bmatrix} 1 & 0 & 0 \\ 0 & \cos a & -\sin a \\ 0 & \sin a & \cos a \end{bmatrix}$$

- `glRotatef(a, 0, 1, 0):`

$$\begin{bmatrix} \cos a & 0 & \sin a \\ 0 & 1 & 0 \\ -\sin a & 0 & \cos a \end{bmatrix}$$

- `glRotatef(a, 0, 0, 1):`

$$\begin{bmatrix} \cos a & -\sin a & 0 \\ \sin a & \cos a & 0 \\ 0 & 0 & 1 \end{bmatrix}$$

- `glTranslatef(x, y, z)`

- How is a translation defined?

- $x_1 = x_0 + x$

- $y_1 = y_0 + y$

- $z_1 = z_0 + z$

!! This is a problem !!

There is no way to represent this as a multiplication of 3x3 matrices

- `glTranslatef(x, y, z)`

- Where there's a will, there's a workaround.
- Use 4x4 matrices!

$$T = \begin{bmatrix} 1 & 0 & 0 & x \\ 0 & 1 & 0 & y \\ 0 & 0 & 1 & z \\ 0 & 0 & 0 & 1 \end{bmatrix}$$

- This actually gives us the correct results:

$$\begin{bmatrix} x_1 \\ y_1 \\ z_1 \\ 1 \end{bmatrix} = \begin{bmatrix} 1 & 0 & 0 & x \\ 0 & 1 & 0 & y \\ 0 & 0 & 1 & z \\ 0 & 0 & 0 & 1 \end{bmatrix} \cdot \begin{bmatrix} x_0 \\ y_0 \\ z_0 \\ 1 \end{bmatrix} = \begin{bmatrix} x_0+x \\ y_0+y \\ z_0+z \\ 1 \end{bmatrix}$$

**you can open your eyes again**



# order of transformations

- Matrix multiplication is not commutative.
- The order of operations is important!
- Example: Rotation and translation

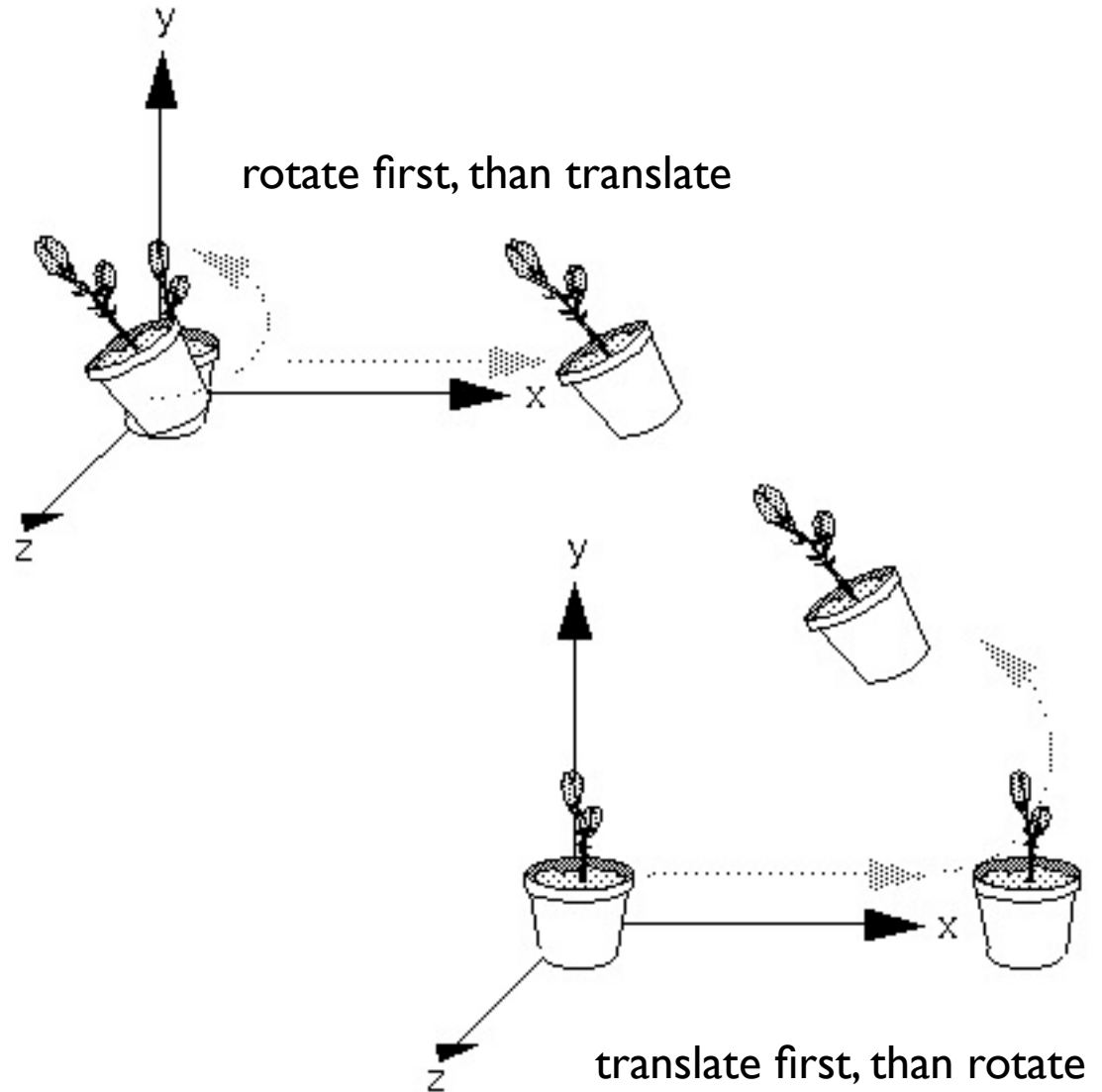

World-space view

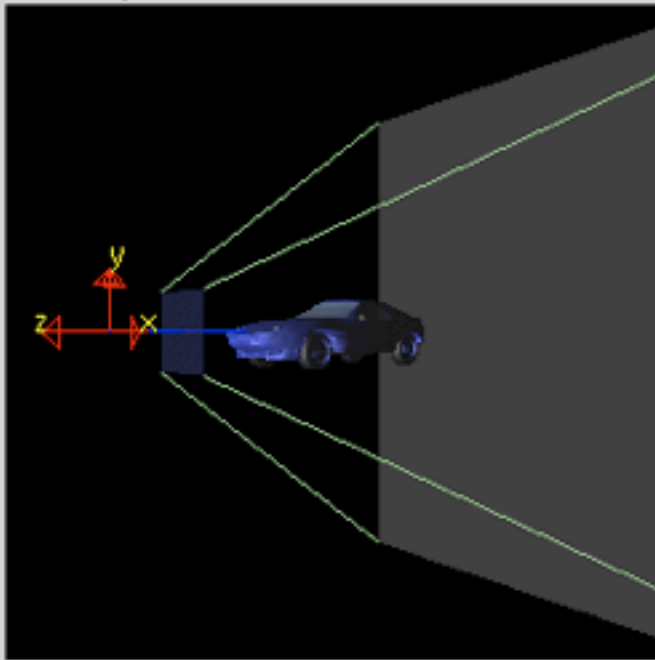

Screen-space view



Command manipulation window

```
glTranslatef( 0.00 , 0.00 , 0.00 );  
glRotatef( 0.0 , 0.00 , 1.00 , 0.00 );  
glScalef( 1.00 , 1.00 , 1.00 );  
glBegin( ... );  
...
```

**Click on the arguments and move the mouse to modify values.**

SDL/OpenGL intro

