

**emcomat 8.4**  
**emcomat 8.6**

**SERVICETEILE**

**SERVICE PARTS**

**PIECES DE SERVICE**

Ref. VS2 318

7610

HERBST

## INDEX

1, 2	Grundausrüstung	Tools	Equipment de base
3, 4	Drehmaschinenbett	Lathe bed	Banc de tour
5, 6	Spindelstock	Headstock	Poupée fixe complete
7, 8	Wendeherz	Gear train holder	Inverseur de marche
9,10	Vorschubgetriebe	Feed gear box	Dispositif d'avance
11,12	Motor	Motor	Moteur
13,14	E-Gehäuse	E-Housing	Boîte électrique
15,16	Schloßplatte	Apron	Tablier
17,18	Längs- und Querschlitzen	Saddle and cross slide	Trainard et Chariot transversal
19,20	Obersupport	Compound	Chariot supérieur
21,22	Reitstock	Tailstock	Contre pointe complète
23,24	Motor für Vertikalvorrichtung	Motor for vertical attachment	Moteur pour colonne verticale
25,26	Rollkörner	Revolving center	Pointe tournante
25,26	Riemenspanner	Tensioning roller	Roleau tendeur
27	Laufelinette	Follower rest	Lunette à suivre
28	Stehelinette	Steady rest	Lunette fixe
29	Spannzangenvorrichtung	Collet attachment	Dispositif de serrage par pinces
30	Schnellspannfutter	Quick action collet chuck	Mandrin à serrage rapide
31,32	Maschinenschraubstock	Clamping vice	Etau
33,34	Teilapparat	Dividing head	Appareil diviseur
35,36	Supportschleifapparat	Toolpost grinder attachment	Dispositif d'affûtage sur support
37,38	Maschinenständer	Machine stand	Montant
39	Rädersatz	Set of change gears	Jeu d'engrenages
39	Scherbolzen	Shaft	Axe filete
40-43	Vertikalvorrichtung	Vertical attachment	Colonne verticale

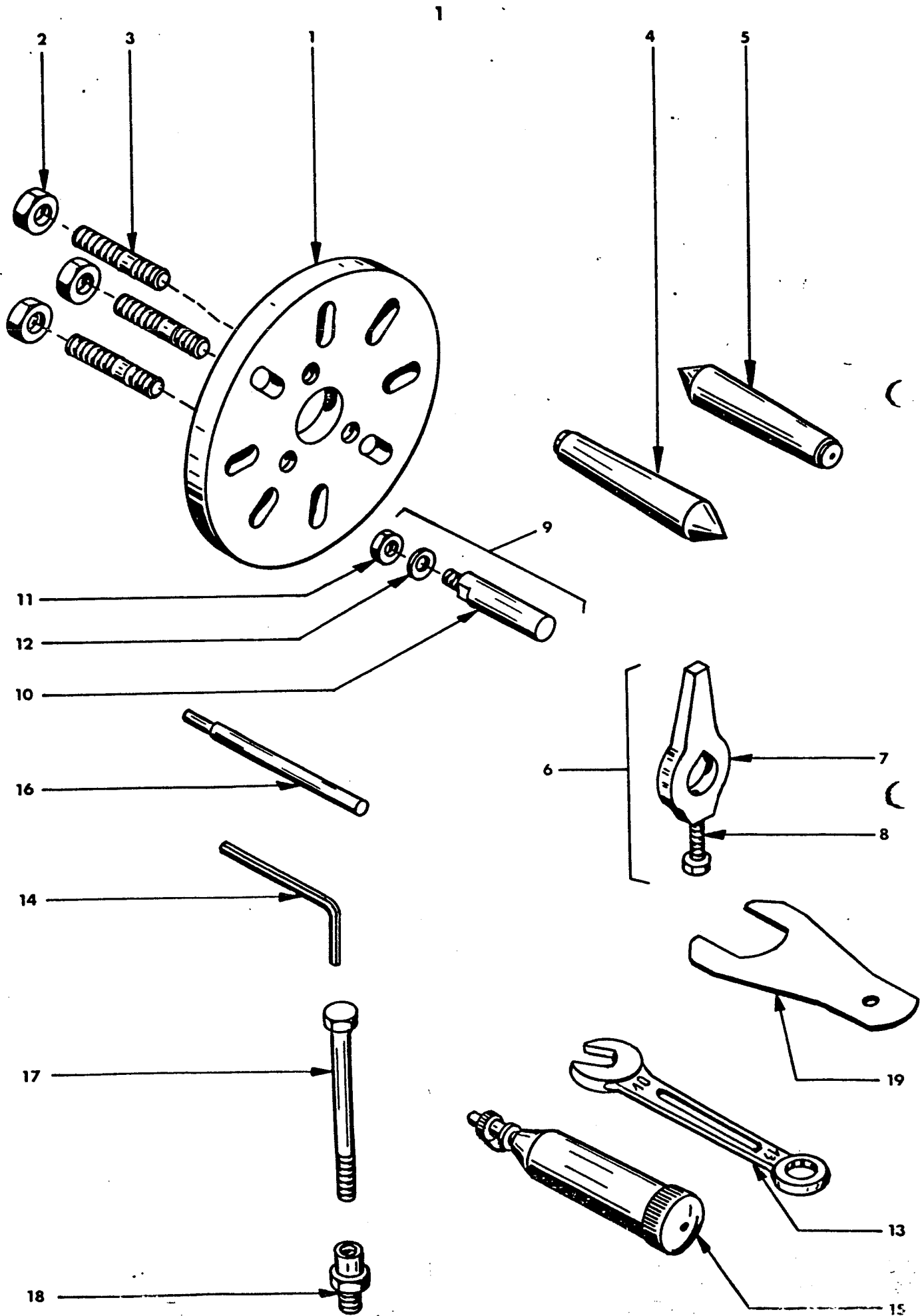

				Grundausrüstung	Tools	Equipment de base
Pos	Ref.No.	DIN		BENENNUNG	DESCRIPTION	DESIGNATION
	B4A 120 000			G.Mitnehmerscheibe	Face plate	Plateau de tour
1	B4A 120 010			Mitnehmerscheibe	Face plate	Plateau de tour
2	ZMU 34 0800			Sechskantmutter	Nut	Ecrou hexagonal
3	ZSR 39 0820			Stiftschraube	Stud	Goujon filetee
4	B2A 000 420			Körnerspitze MK 2	Centre MT 2	Pointe fixe CM 2
5	B2A 000 460			Körnerspitze MK 3	Centre MT 3	Pointe fixe CM 3
6	B2A 130 000			Gr. Drehherz	Lathe dog	Toc de tour
7	B2A 130 010			Drehherz	Lathe dog	Toc de tour
8	ZSR 33 0840	M8x40 DIN 933		Sechskantschraube	Hexagon screw	Vis 6 pans
9	B2A 140 000			Gr. Mitnehmer	Holding bolt	Entraineur
10	B2A 140 010			Mitnehmerbolzen	Holding bolt	Entraineur de toc
11	ZMU 34 0800	M8 DIN 934		Mutter	Nut	Ecrou hexagonal
12	ZSB 25 0840	B8,4 DIN 125		Scheibe	Washer	Rondelle plate
13	B2A 000 470			Universalschlüssel	Key wrench	Clé à molette
14	A2Y 030 010			Sechskantstiftschlüssel	Hexagonal key	Clé à six pans
15	ZWZ 99 0012			Kleinfettresse	Grease gun	Pompe de graissage
				Vertikalvorrichtung	Vertical attachment	Colonne vertical
16	E1A 000 310			Abdrückstift	Pin	Goupille
17	E1A 000 300			Anzugschraube	Draw bar	Vis de tension
18	E1A 000 210			Reduzierschraube	Sleeve	Vis pour tige de rappel
19	E1A 000 320			Schlüssel	Key wrench	Clé de broche

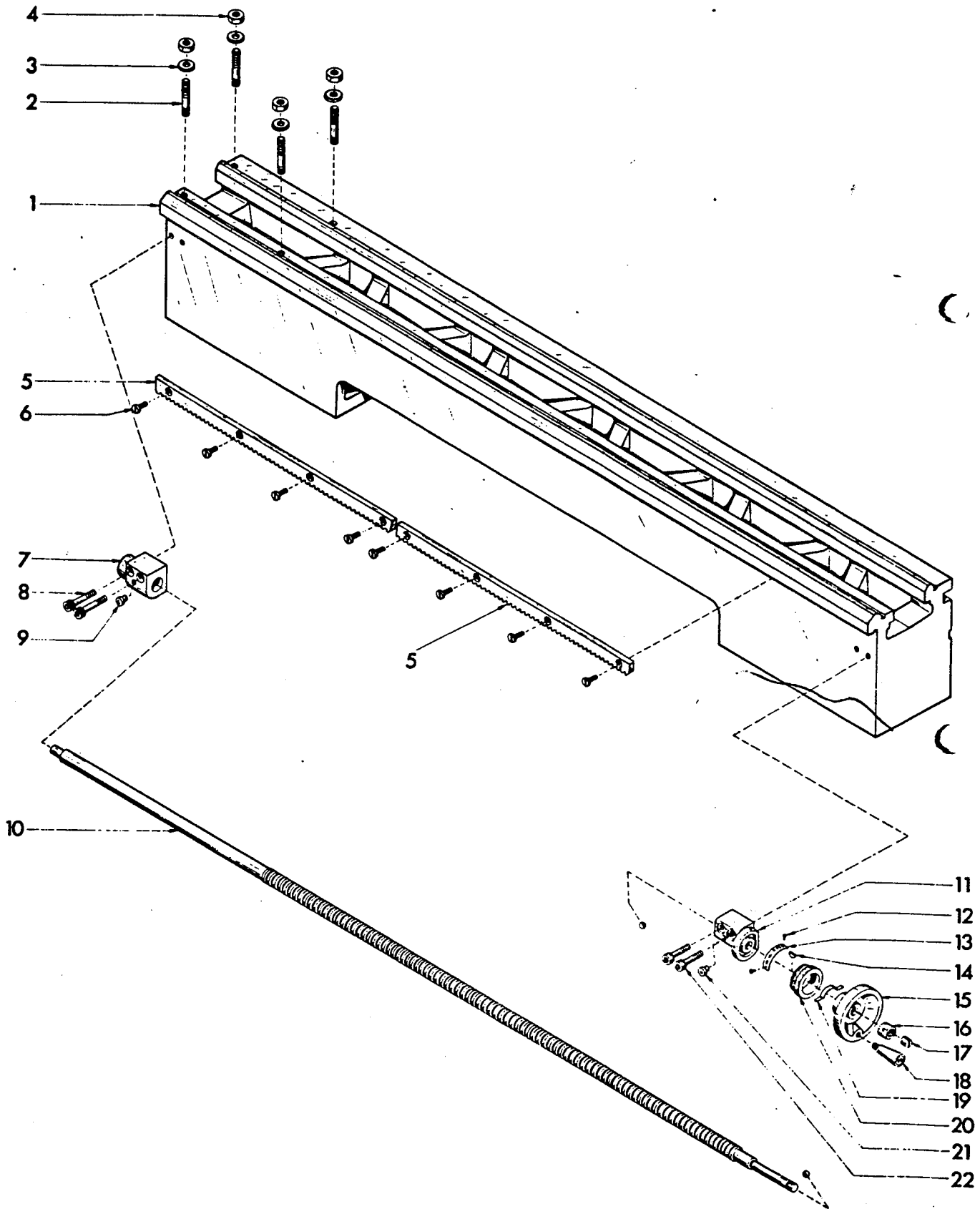

				Drehmaschinenbett	Lathe bed	Banc de tour
Pos	Ref.No.	DIN		BENENNUNG	DESCRIPTION	DESIGNATION
1	B4F 000 010			Bett EMCOMAT 8.4	Bed EMCOMAT 8.4	Banc EMCOMAT 8.4
1	B4A 000 011			Bett EMCOMAT 8.6	Bed EMCOMAT 8.6	Banc EMCOMAT 8.6
2	ZSR 39 0820	M8x20 DIN 939		Stiftschraube	Stud	Goujon fileté
3	ZSB 25 0840	B8,4 DIN 125		Scheibe	Washer	Rondelle
4	ZMU 34 0800	M8 DIN 934		Sechskantmutter	Nut	Ecrou hexagonal
5	B2A 000 020			Zahnstange	Rack	Crémaillère
5	B4A 000 020			EMCOMAT 8.4	EMCOMAT 8.4	EMCOMAT 8.4
				Zahnstange	Rack	Crémaillère
6	ZSR 84 0410	M4x10 DIN 84		EMCOMAT 8.6	EMCOMAT 8.6	EMCOMAT 8.6
7	B2A 000 030			Zylinderschraube	Flat head screw	Vis tête cylindrique
8	ZSR 12 0630	M6x30 DIN 912		Leitspindelträger	Bearing block	Support de vis mère
9	ZNP 01 1000			Innensechskantschraube	Allen head screw	Vis six pans creux
10	B2A 000 050			Schmiernippel	Grease fitting	Graisseur
				Leitspindel M	Lead screw M	Vis mère M
10	B2B 000 050			EMCOMAT 8.4	EMCOMAT 8.4	EMCOMAT 8.4
				Leitspindel Ww	Lead screw Ww	Vis mère Ww
10	B3A 000 050			EMCOMAT 8.4	EMCOMAT 8.4	EMCOMAT 8.4
				Leitspindel M	Lead screw M	Vis mère M
10	B3B 000 050			EMCOMAT 8.6	EMCOMAT 8.6	EMCOMAT 8.6
				Leitspindel Ww	Lead screw Ww	Vis mère Ww
				EMCOMAT 8.6	EMCOMAT 8.6	EMCOMAT 8.6
				Leitspindelträger	Bearing block	Support de vis mère
11	S2A 000 040			Kerbnagel	Rivet	Vis à tête fendue
12	ZNA 76 0144	1,4x4 DIN 1476		Skalenschild M	Plate M	Plaque indicatrice M
13	B2A 000 060			Skalenschild Ww	Plate Ww	Plaque indicatrice Ww
13	B2B 000 060			Scheibenfeder	Key	Clavette de poulie
14	ZFD 88 0337	3x3,7 DIN 6888		Handrad	Handwheel	Volant
15	B4A 000 030			Mutter	Nut	Ecrou hexagonal
16	B2A 000 100			Gewindestift	Set screw	Vis réglage
17	ZST 51 0806	M8x6 DIN 551		G. Kegelgriff	Handle	Levier spherique
18	B2A 013 000			Bogenfeder	Feed spring	Ressort d'avance
19	B2A 000 080			Skalenring M	Micrometer collar M	Vernier M
20	B2A 000 090			Skalenring Ww	Micrometer collar Ww	Vernier Ww
20	B2B 000 090			Schmiernippel	Grease fitting	Graisseur
21	ZNP 01 1000			Innensechskantschraube	Allen head screw	Vis six pans creux
22	ZSR 12 0625	M6x25 DIN 912				

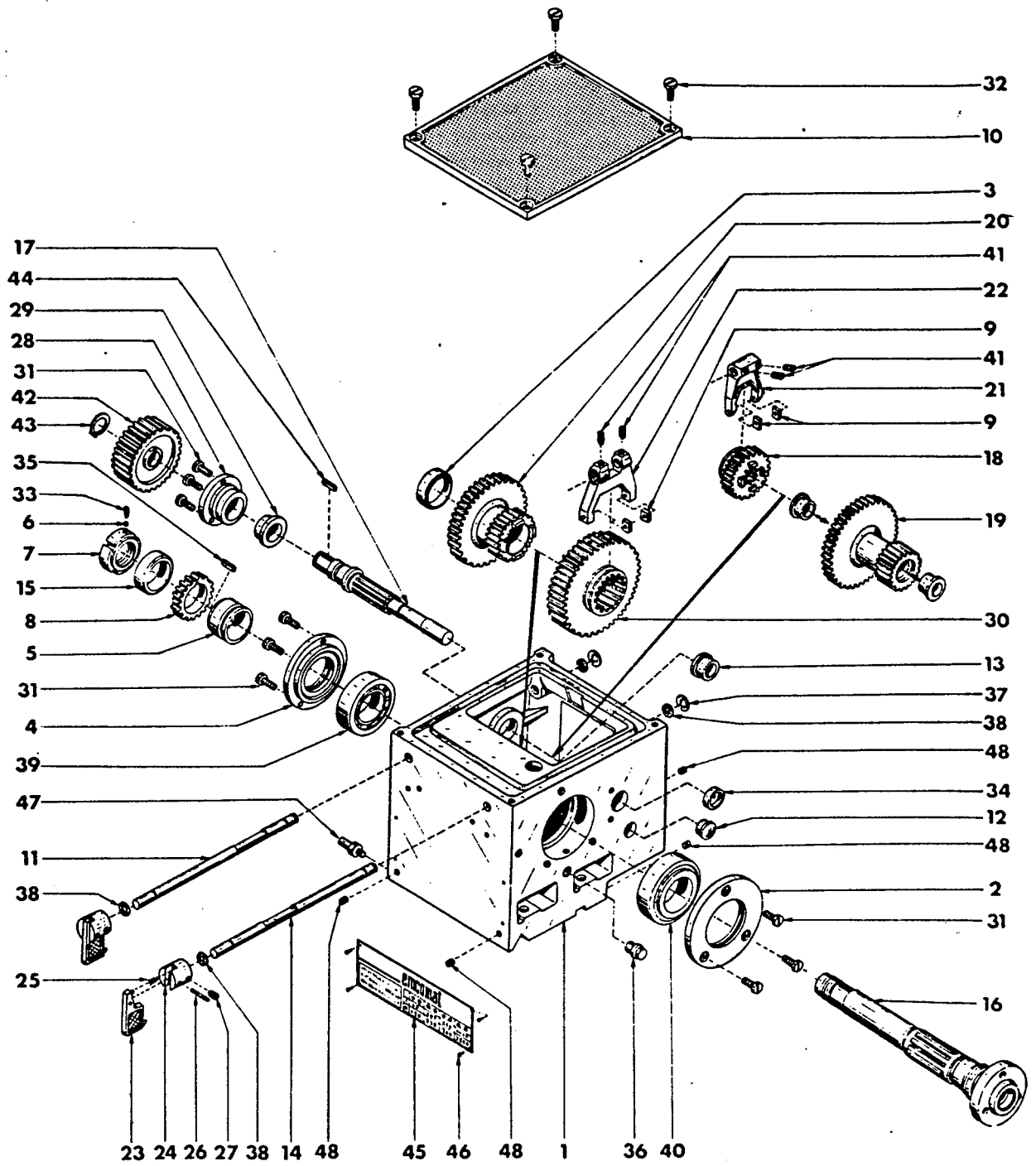

	B4F 030 000 B4G 030 000			G. SpindelstockM G. Spindelstock CH	Headstock M Headstock CH	Poupée fixe M Poupée fixe CH
Pos	Ref.No.	DIN		BENENNUNG	DESCRIPTION	DESIGNATION
1	B4A 030 010			Spindelstock	Headstock	Poupée fixe
2	B4A 030 020			Lagerdeckel	Cover	Couvercle de roulement
3	B2A 030 030			Zwischenring	Intermediate	Bague intermediaire
4	B2A 030 040			Lagerdeckel	Cover	Couvercle de roulement
5	B2A 030 050			Dichtring	Gasket	Joint de feutre
6	B2A 030 060			Druckscheibe	Disc	Rondelle pointeau
7	B2A 030 070			Spannmutter	Nut	Ecrou cranté
8	B2A 030 080			Zahnrad z=35	Gear 35	Pignon de rechange 35
9	B2A 030 090			Gleitstein	Sliding contact	Glissière
10	B2A 030 100			Deckplatte	Cover	Couvercle de roulement
11	B2A 030 110			Schaltstange I	Wiper I	Axe de commande I
12	B2A 030 120			Ölstandsauge	Oil level gauge	Indicateur d'huile
13	B2A 030 130			Bundlager	Journal bearing	Palier coussinet
14	B2A 030 140			Schaltstange II	Wiper II	Axe de commande II
15	B2A 030 150			Distanzring	Bushing	Entretoise
	B4F 030 160			Spindel M	Spindle M	Broche principaleM
16	BFG 030 160			Spindel CH	Spindle CH	Broche principaleCH
17	B2A 030 170			Getriebewelle	Shaft	Arbre principal
18	B2A 030 180			Schaltrad z=28	Gear	Roue de guidage
19	B2A 031 000			Gr. Zahnradblock z=56 z=23	Gear wheel	Pignon
20	B2A 032 000			Gr. Zahnradblock z=56 z=28	Gear wheel	Pignon
21	B2A 033 000			Gr. Schaltgabel I	Selector shift fork lever	Sous groupe fourche d'embrayage
22	B2A 034 000			Gr. Schaltgabel II	Selector shift fork lever	Sous groupe fourche d'embrayage
	B2A 035 000			G. Schalthebel	Lever switch	Manette
23	B2A 035 010			Schalthebel	Lever switch	Manette
24	B2A 035 020			Schaltnabe	Hub	Moyeu
25	B2A 010 080			Druckfeder	Spring	Ressort de pression
26	ZHL 81 0322	3x22 DIN 1481		Spannhülse	Thimble	Axe
27	ZST 16 0608	AM6x8 DIN 916		Gewindestift	Set screw	Vis
	B2A 036 000			G. Lagerdeckel	Cover	Fiasque de roulement
28	B2A 036 010			Lagerdeckel	Cover	Fiasque de roulement
29	B2A 036 020			Bundbüchse	Lead screw bearing	Bagije du roulement
30	B2A 037 000			Gr. Zahnradblock z=61	Gear wheel	Pignon
31	ZSR 84 0508	M5x8 DIN 84		Zylinderschraube	Flat head screw	Vis cylindriques
32	ZSR 84 0512	M5x12 DIN 84		Zylinderschraube	Flat head screw	Vis cylindriques
33	ZST 17 0405	M4x5 DIN 417		Gewindestift	Set screw	Vis pointeau
34	ZDK 43 1800			Verschlußdeckel	Cover	Bagije
35	ZFD 85 3316	A3x3x16 DIN 6885		Paßfeder	Key	Clavette
36	ZSR 10 1010	M10x1 DIN 910		Verschlußschraube	Closing screw	Vis de vidange
37	ZRG 71 0808	8x0,8 DIN 471		Sicherungsring	Ring	Circlips
38	ZRG 00 5800	RS5x8		Rundschnurring	Rubber-belt	Joint caoutchouc
39	ZLG 32 0066	32 006 XC/P6		Kegelrollenlager	Heavy taper roller bearings	Roulements à rouleaux coniques
40	ZLG 32 0076	32 007 XC/P6		Kegelrollenlager	Heavy taper roller bearings	Roulements à rouleaux coniques
41	ZST 16 0508	AM5x8 DIN 916		Gewindestift	Set screw	Vis
	B2A 100 050			Riemenscheibe (50Hz)	Pulley (50Hz)	Poulie (50Hz)
42	B2B 100 050			Riemenscheibe (60Hz)	Pulley (60Hz)	Poulie (60Hz)
43	ZRG 71 1310	13x1 DIN 471		Sicherungsring	Ring	Circlips
44	ZFD 85 4416	A4x4x16 DIN 6885		Paßfeder	Key	Clavette
45	B4A 000 540			Drehzahlschild	Speed plate	Plaque indicatrice des vitesses
46	ZNA 76 0144	1,4x4 DIN 1476		Halbrundkerbnagel	Rivet	Vis à tête fendue
47	B2A 000 650			Schraube	Screw	Vis
48	ZST 51 0408	M4x8 DIN 551		Gewindestift	Set screw	Vis



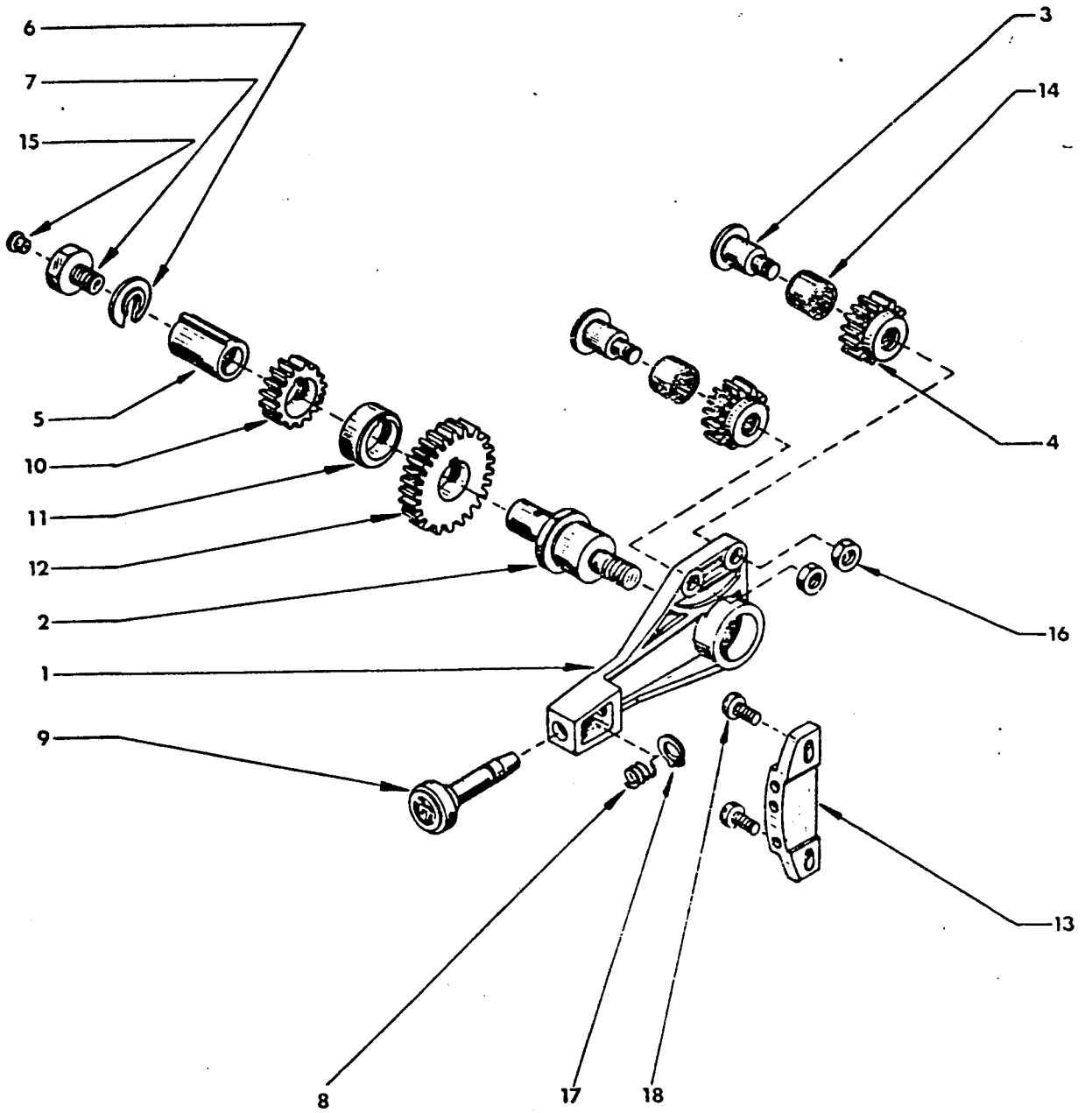

	B2A 060 000			G. Wendeherz	Gear train holder	Inverseur de marche
Pos:	Ref.No.	DIN		BENENNUNG	DESCRIPTION	DESIGNATION
1	B2A 060 010			Wendeherz	Gear train holder	Inverseur
2	B2A 060 020			Herzbolzen	Shaft	Axe fileté principal
3	B2A 060 030			Wendebolzen	Shaft	Axe fileté d'inverseur
4	B2A 060 040			Wenderad	Gear	Pignon d'inverseur
5	B2A 060 050			Keilhülse	Bush	Douille
6	B2A 000 450			Sicherungsring	Horse-shoe clip	Bague fendue "Seeger"
7	B2A 060 060			Sicherungsschraube	Safety screw	Vis de sûreté
8	B2A 060 070			Druckfeder	Feed spring	Ressorts de positionnement
9	B2A 061 000			G. Absteckknebel	Locking pin	Bouton d'enclanchement
10	B2A 000 250			Wechselrad z=20	Gear	Pignon intermediaire
11	B2A 000 280			Zwischenring	Bushing	Bague d'ecartement
12	B2A 000 290			Wechselrad z=35	Gear	Pignon intermediaire
13	B2A 000 320			Segment	Locking section	Secteur de positionnement
14	ZLG 78 1010			Nadelhülse	Needle bearing	Roulement à aiguilles
15	ZNP 01 1000			Schmiernippel	Grease fitting	Graisseur
16	ZMU 39 0500	M5 DIN 439		Sechskantmutter	Hex screw	Vis hexagonale
17	ZRG 71 0506	5x0,6 DIN 471		Sicherungsring	Clip	Circlip
18	ZSR 84 0410	M4x10 DIN 84		Zylinderschraube	Flat head screw	Vis cylindriques

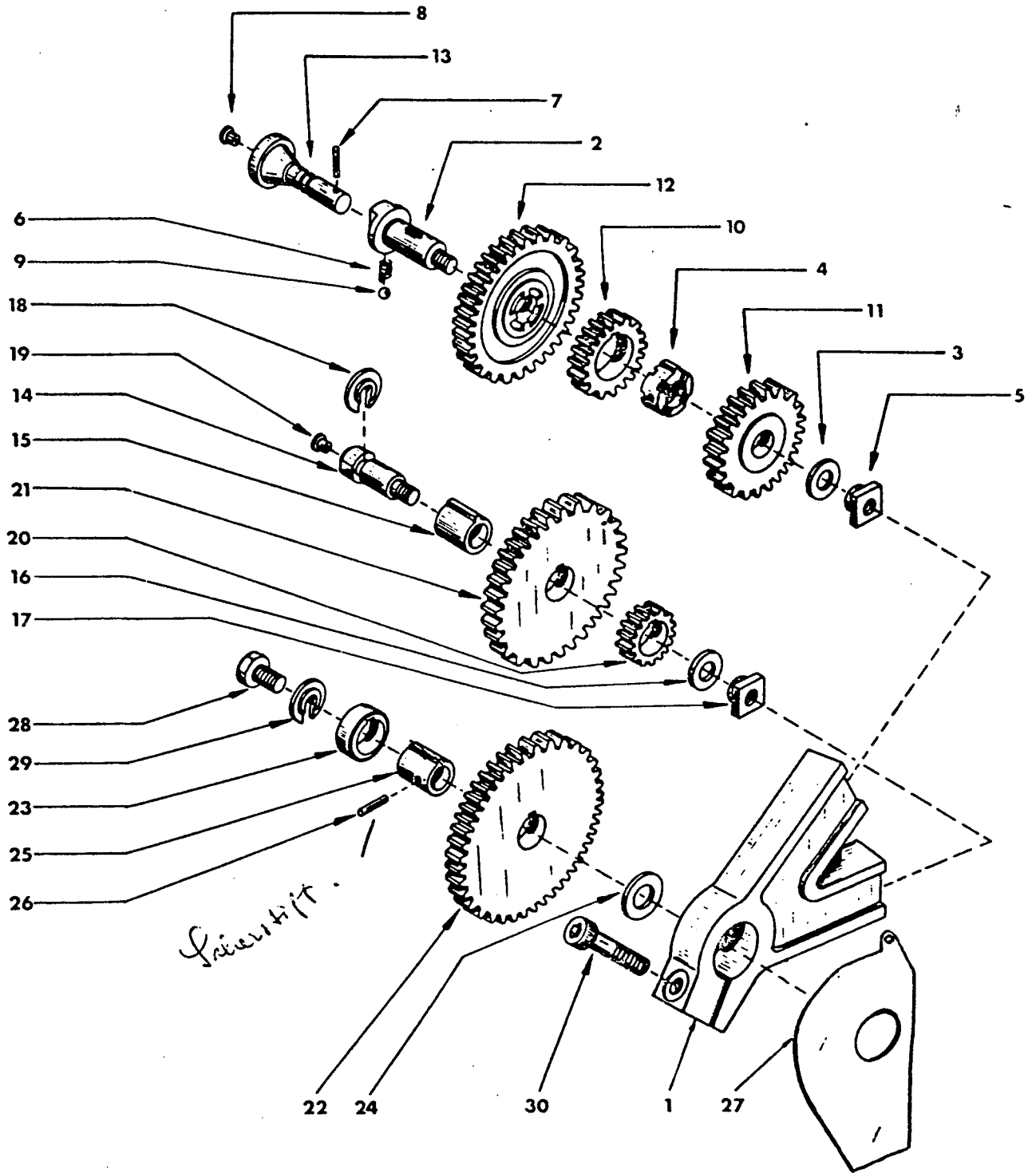

	B2A 070 000			G. Vorschubgetriebe	Feed gear box	Dispositif d'avance
Pos	Ref.No.	DIN		BENENNUNG	DESCRIPTION	DESIGNATION
1	B2A 070 010			Räderschere	Quadrant	Lyre
2	B2A 071 000			Gr. Vorschub	Feed gear box	Dispositif d'avance
3	B2A 071 010			Vorschubbolzen	Bolt	Boulon
4	B2A 071 020			Scheibe	Washer	Rondelle
5	B2A 071 030			Kupplung	Coupling part	Eléments d'accouplement
6	B2A 071 040			Nutenstein	T-nut	Boulon tête carrée
7	B2A 071 050			Druckfeder	Feed Spring	Ressort d'avance
8	ZHL 81 0256	2,5x16 DIN 1481		Spannhülse	Thimble	Pion de centrage
9	ZNP 01 1000			Schmiernippel	Grease fitting	Graisseur
10	ZKG 00 1030	3,0 GK3 DIN5401		Stahlkugel	Ball	Bille
11	B2A 072 000			Gr. Vorschubrad z=30	Gear 30	Pignon 30 dents
12	B2A 073 000			Gr. Vorschubrad z=45	Gear 45	Pignon 45 dents
13	B2A 074 000			Gr. Vorschubrad z=60	Gear 60	Pignon 60 dents
14	B2A 075 000			Gr. Schaltknopf	Lever switch	Manette
15	B2A 076 000			Gr. Scherbolzen	Shaft	Axe fileté
16	B2A 076 010			Scherbolzen	Shaft	Axe fileté
17	B2A 000 310			Keilhülse	Bush	Bague
18	B2A 071 020			Scheibe	Washer	Rondelle
19	B2A 071 040			Nutenstein	T-nut	Boulon tête carrée
20	B2A 000 450			Sicherungsring	Clip	Bague fendue
21	ZNP 01 1000			Schmiernippel	Grease fitting	Graisseur
22	B2A 000 250			Wechselrad z=20	Gear	Pignon 20dents
23	B2A 000 260			Wechselrad z=75	Gear	Pignon 75dents
24	B2A 000 270			Wechselrad z=80	Gear	Pignon 80dents
25	B2A 000 280			Zwischenring	Bushing	Bague d'écartement
26	B2A 000 300			Scheibe	Washer	Rondelle
27	B2A 000 310			Keilhülse	Bush	Bague à clavette
28	B2A 000 350			Scherstift	Bushing	Goupille de cisaillement
29	B2A 000 640			Abdeckblech	Cover mount	Couvercle
30	ZSR 33 0610	M6x10 DIN 933		Sechskantschraube	Hexagonal screw	Vis hexagonal
31	B2A 000 450			Sicherungsring	Clip	Bague fendue
32	ZSR 12 0630	M6x30 DIN 912		Innensechskantschraube	Allen head screw	Vis six pans creux

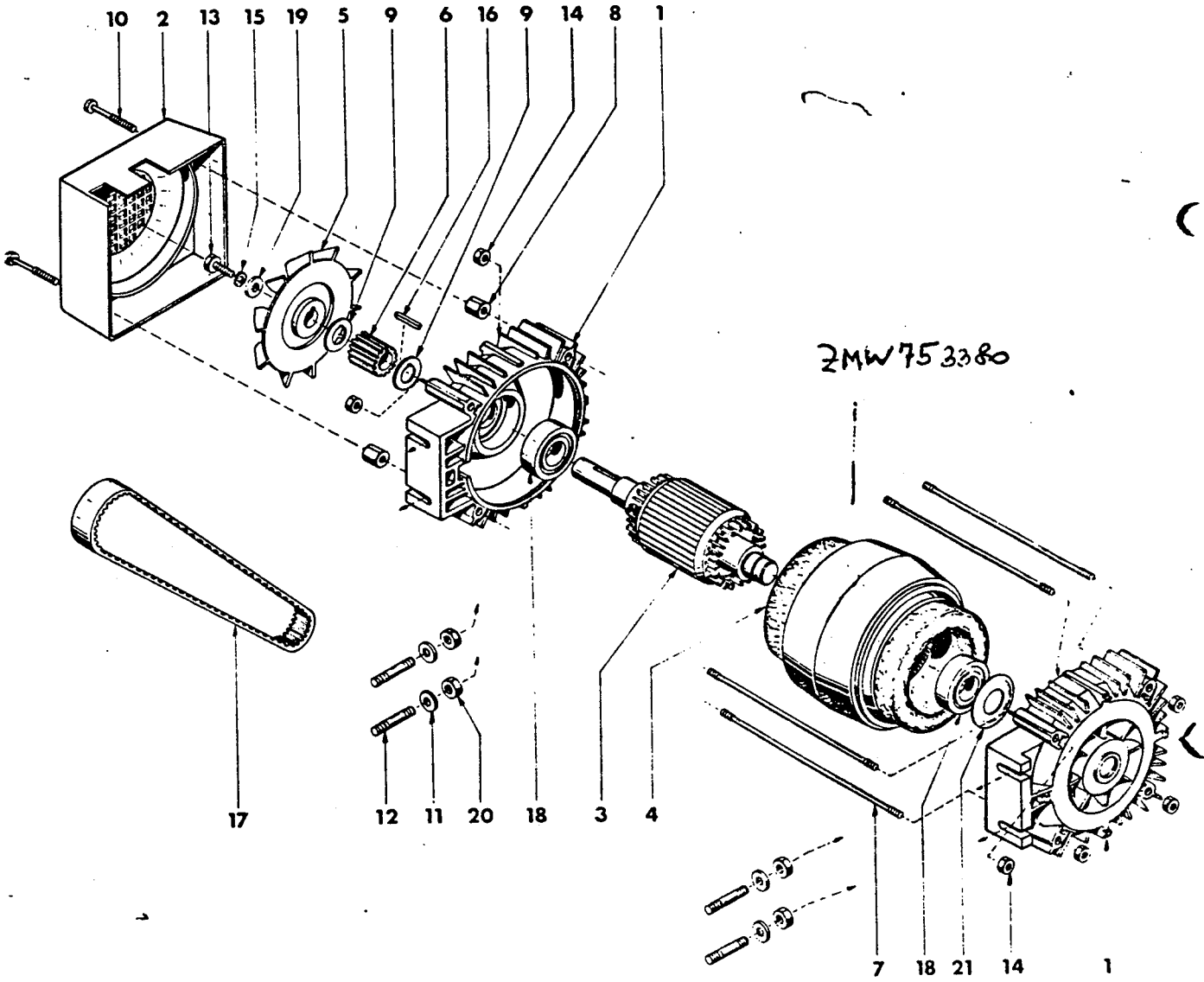

2MW753380

контрп. 7ME50

				Motor ELIN	Motor ELIN	Moteur ELIN
Pos	Ref.No.	DIN		BENENNUNG	DESCRIPTION	DESIGNATION
1	B2A 100 062			Lagerschild	Bearing bracket	Flasque à ailettes
2	B2A 000 440			Lüfterhaube	End shield	Carter de ventilateur
3	ZML 75 1000			Rotor*)	Rotor*)	Rotor*)
4				Stator*)	Stator*)	Stator*)
5	B2A 100 110			Lüfterflügel	Fan	Ventilateur
	B2A 100 100			Motorriemenscheibe z=18	Motor pulley	Poulie grantée de mot,-50 périod.
6	B2B 100 100			Motorriemenscheibe z=16	Motor pulley	Poulie grantée de mot,-60 périod.
7	B2A 100 070			Gehäuseschraube	Casing screw	Tirants d'assemblage
8	B2A 100 080			Gehäusemutter	Casing nut	Ecrou de boîtier
9	B2A 100 090			Scheibe	Washer	Rondelle
10	ZSR 84 0530	M5x30 DIN 84		Zylinderschraube	Flat head screw	Vis cylindrique
11	ZSB 21 0640	A6,4 DIN 9021		Scheibe	Washer	Rondelle
12	ZSR 39 0820	M8x20 DIN 939		Stiftschraube	Stud	Goujon
13	ZSR 38 0620	M6x20 DIN 938		Sechskantschraube	Hexagonal screw	Vis hexagonal
14	ZMU 34 0500	M5 DIN 934		Mutter	Nut	Ecrou hexagonal
15	ZSB 98 0640	A6,4 DIN 6798		Fächerscheibe	Spring washer	Ressort hélicoïdal
16	ZFD 85 4432	A4x4x32 DIN6885		Paßfeder	Spring	Clavette
17	ZRM 51 4200	200 XL 100		Zahnriemen	Timing belt	Courroie crantée
18	ZLG 60 0402	6004 - 2Z		Kugellager	Ball bearing	Roulements à billes
19	B2A 100 120			Beilagscheibe	Washer	Rondelle
20	ZMU 34 0800	M8 DIN 934		Mutter	Nut	Ecrou hexagonal
21	B2A 100 090			Scheibe	Washer	Rondelle

- \*) Bei Bestellung bitte Spannung und Frequenz angeben.  
 In your order please indicate voltage and frequency.  
 A la commande specifier le voltage et la frequence du moteur.

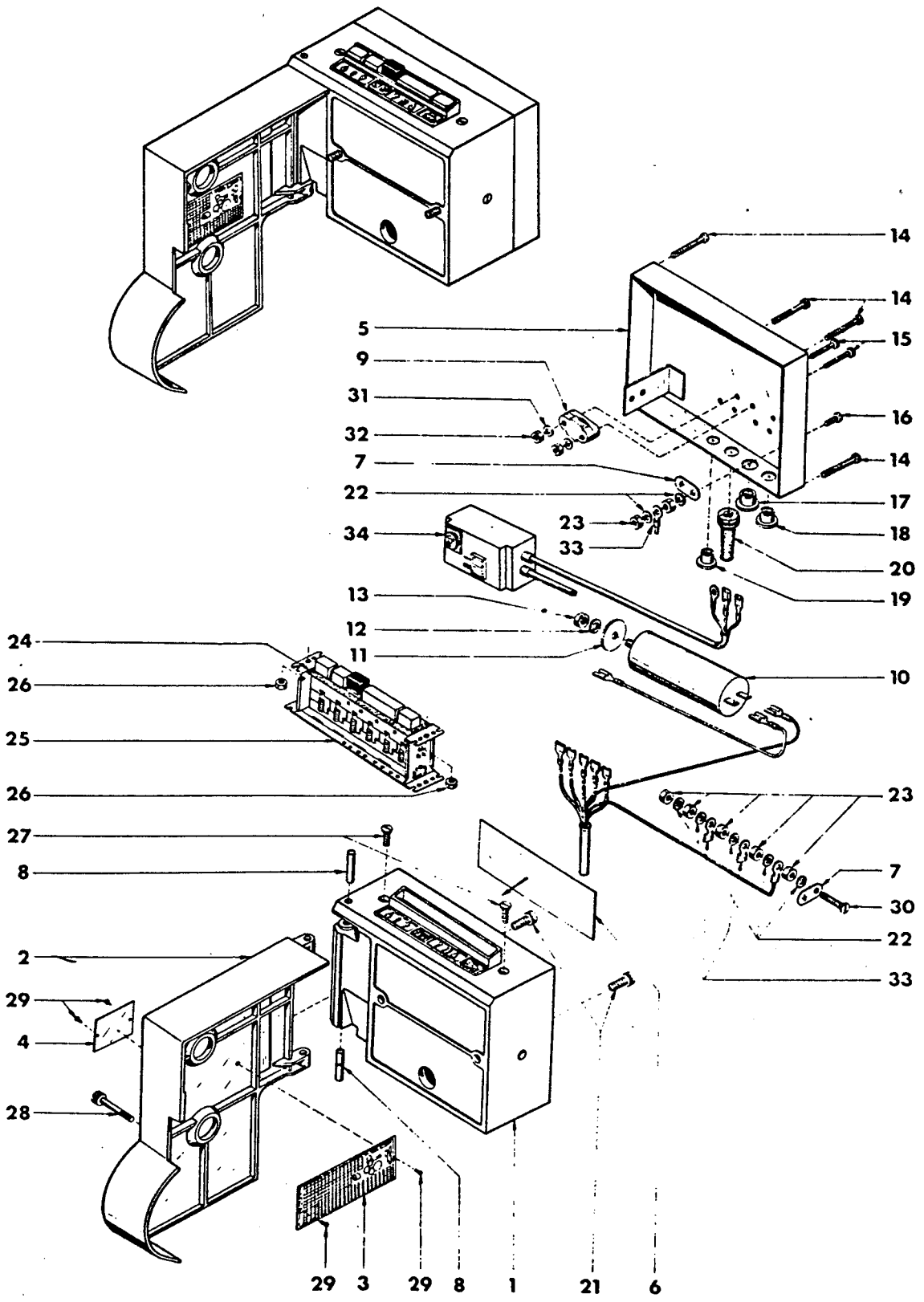

			E-Gehäuse	E-housing	Boîte électrique
Pos	Ref.No.	DIN	BENENNUNG	DESCRIPTION	DESIGNATION
1	B2A 000 391		E-Gehäuse	E-housing	Boîte électrique
2	B2A 000 402		Vorschubdeckel	Dome	Carter pivotant
	B2A 000 410		Gewindetabelle M	Thread cutting chart M	Tableau des avances M
3	B2B 000 410		Gewindetabelle Ww	Thread cutting chart Ww	Tableau des avances Ww
4	B2A 000 621		Schild	Plaid	Plaque
5	B2A 101 001		G. Deckel	Roofing	Couvercle
6	B2A 000 380		Isofierplatte	Insulating plate	Plaque isolante
7	H1E 100 010		Erdungsschild	Earthing plaid	Plaque mise à la terre
8	ZST 06 0632	6M6x32 DIN 7	Zylinderstift	Pin	Axa carta
9	ZEL 99 0101		Zugentlastungsschelle	Clip	Collier
	ZKO 15		Kondensator 35µF 330V	Condenser 35µF 330V	Condensateur 35µF 330V
10	ZKO 15 2540		Kondensator 40µF 330V	Condenser 40µF 330V	Condensateur 40µF 330V
	ZKO 15 2550		Kondensator 50µF 330V	Condenser 50µF 330V	Condensateur 50µF 330V
11	B2A 100 030		Scheibe 40	Washer 40	Rondelle 40
12	ZRG 28 0080	B8 DIN 127	Federring	Clip	Bague de sécurité
13	ZMU 34 0800	M8 DIN 934	Mutter	Nut	Ecrou
14	ZSR 84 0440	M4x40 DIN 84	Zylinderschraube	Flat head screw	Vis cylindriques
15	ZSR 84 0430	M4x30 DIN 84	Zylinderschraube	Flat head screw	Vis cylindriques
16	ZSR 83 0410	M4x10 DIN 84	Zylinderschraube	Flat head screw	Vis cylindriques
17	ZDK 60 0018	F18	Verschlußstopfen	Stopper	Bouchon
18	ZDK 60 0012	F12	Verschlußstopfen	Stopper	Bouchon
19	ZDK 60 0010	F10	Verschlußstopfen	Stopper	Bouchon
20	ZEL 70 0080	T-8	Knickschutztülle	Protective coating	Passe-fil en caoutchouc
21	ZSR 12 0816	M8x16 DIN 912	Zylinderschraube	Flat head screw	Vis cylindriques
22	ZSB 97 0430	A4,3 DIN 6797	Zahnscheibe	Clip	Bague de sécurité
23	ZMU 34 0401	M4 DIN 934	Sechskantmutter	Nut	Ecrou
24	B2A 100 020		Schaumstoffdichtung	Plastik dirt seal	Garniture etange caoutchouc
	ZEL 17 1000		Drucktastenschalter 1ph	Push button switch 1ph	Interrupteur monophasé
25	ZEL 17 1001		Drucktastenschalter 1ph CSA	Push button switch 1ph CSA	Interrupteur monophasé CSA
	ZEL 17 3000		Drucktastenschalter 3ph	Push button switch 3ph	Interrupteur 3-phase
26	ZMU 34 0400	M4 DIN 934	Mutter	Nut	Ecrou
27	ZSR 92 0412	M4x12 DIN 964	Linsensenkschraube	Flat head screw	Vis tête fraisée
28	ZSR 12 0640	M6x40 DIN 912	Innensechskantschraube	Allen head screw	Vis six pans creux
29	ZNA 76 0144	1,4x4 DIN 1476	Kernnagel	Rivet	Rivet de fixation
30	ZSR 92 0430	M4x30 DIN 964	Linsensenkschraube	Flat head screw	Vis tête fraisée
31	ZRG 28 0040	B4 DIN 127	Federring	Clip	Bague de sécurité
32	ZMU 34 0400	M4 DIN 934	Sechskantmutter	Nut	Ecrou
33	ZEL 16 0002	32 8527 AMP	Kabelschuh	Cable shoe	Cosse
	B2V 109 000		Stromausfallschutz 220V	Contacteur 220V	Contacteur 220V
34	B2V 119 000	nur VDE	Stromausfallschutz 380 V	Contacteur 380V	Contacteur 380V



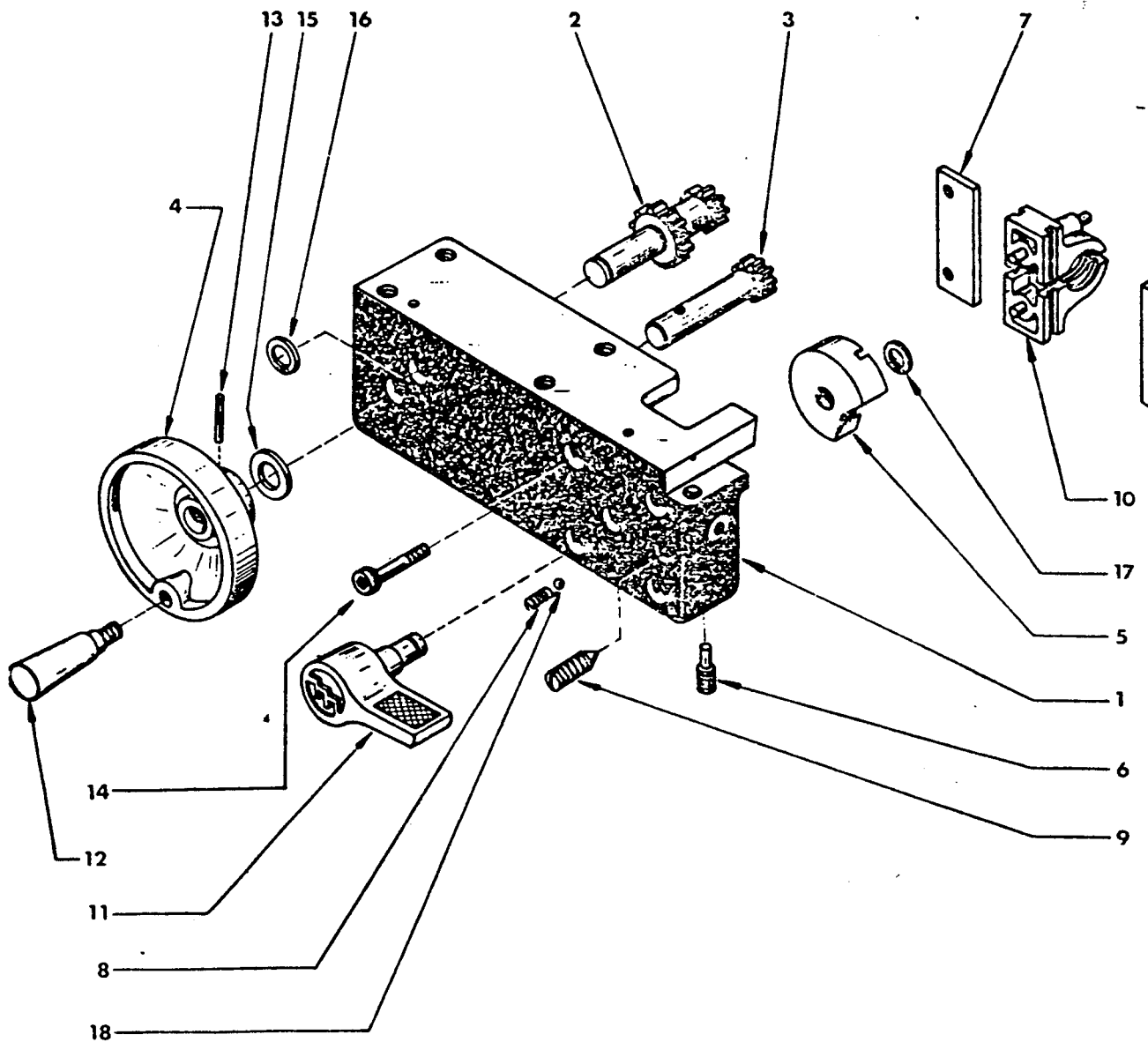

DIN	BENENNUNG	DESCRIPTION	DESIGNATION
	G. Schloßplatte M G. Schloßplatte Ww	Apron M Apron Ww	Tablier M Tablier Ww
	Schloßplatte Zwischenrad Ritzel Handrad Schloßscheibe Nachstellschraube Führungsschiene Druckfeder Einstellschraube	Apron casting Gear Shaft gear Hand wheel Locking cam Adjusting screw Guide Feed spring Adjusting screw	Tablier Pignon double Pignon de volant Volant Boftier Vis pointeau Languette de guidage Ressort d'avance Vis de réglage
	Gr. Schloßmutter M Gr. Schloßmutter Ww Gr. Schloßhebel Gr. Kegelgriff	Half nut M Half nut Ww Handle Handle	Noix M Noix Ww Levier d'enclanchement Manneton
DIN 1481 DIN 912 12x0,9 DIN	Spannhülse Innensechskantschraube Tellerfeder	Grooved pin Allen head screw Spring washer	Clavette fendue Vis six pans creux Rondelle grover
K3 DIN 5401	Sprengring Sprengring Stahlkugel	Clip Clip Ball	Bague de sécurité Bague de sécurité Bille

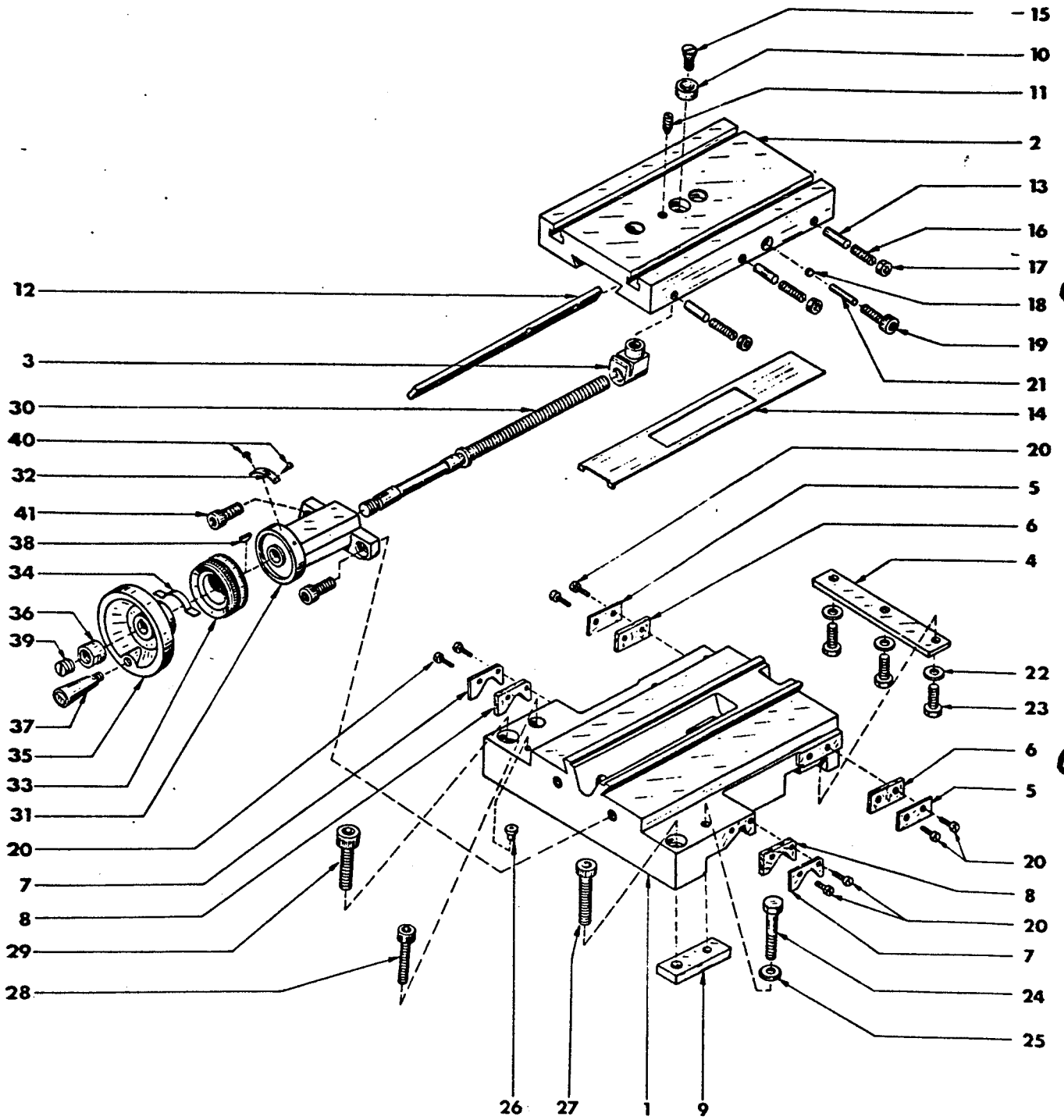

				Längs- und Querschlitzen	Saddle and Cross Slide	Trainard et Chariot transversal
Pos	Ref.No.	DIN		BENENNUNG	DESCRIPTION	DESIGNATION
1	B4A 000 110			Schlitten	Carriage	Trainard
2	B4A 000 120			Querschlitzen	Cross-slide table	Support transversal
	B2A 000 130			Quermutter M	Cross-slide nut M	Ecrou de vis transversale M
3	B2B 000 130			Quermutter Ww	Cross-slide nut Ww	Ecrou de vis transversale Ww
4	B2A 000 180			Bettleiste	Gib	Plaque de guidage
5	B4A 000 170			Abstreifer	Cover mount	Couvercle
6	B4A 000 180			Abstreiffilz	Way cover	Joint d'étanchétée en feutre
7	B4A 000 190			Abstreifer	Cover mount	Couvercle
8	B4A 000 200			Abstreiffilz	Way cover	Joint d'étanchétée en feutre
9	B2A 000 660			Klemmstück	Binding piece	1/2 noix supérieure de blocage
10	B2A 000 150			Senkscheibe	Bushing	Rondelle conique
11	B2A 000 140			Nachstellschraube	Adjusting screw	Vis pointeau
12	B2A 000 210			Einstelleiste	Gib	Plaque de guidage
13	B2A 000 220			Druckstift	Stud	Vis pour lardon
14	B4A 000 240			Deckblech	Cover mount	Couvercle
15	ZSR 63 0612	M6x12 DIN 963		Senkschraube	Flat head screw	Vis tête fraisée
16	ZST 51 0412	M4x12 DIN 551		Gewindestift	Set screw	Vis réglage
17	ZMU 34 0400	M4 DIN 934		Sechskantmutter	Nut	Ecrou hexagonal
18	ZKG 00 2316	3/16 GK3 DIN5401		Stahlkugel	Ball	Bille acier
19	ZSR 12 0616	M6x16 DIN 912		Innensechskantschraube	Allen head screw	Vis six pans creux
20	ZSR 84 0408	M4x8 DIN 84		Zylinderschraube	Flat head screw	Vis cylindrique
21	ZST 08 0512	5H8x12 DIN 7		Zylinderstift	Flat screw	Vis réglage
22	ZSB 25 0530	B5,3 DIN 125		Scheibe	Washer	Rondelle
23	ZSR 33 0516	M5x16 DIN 933		Sechskantschraube	Hexagon head screw	Boulon hexagonal
24	ZSR 31 0635	M6x35 DIN 931		Sechskantschraube	Hexagon head screw	Boulon hexagonal
25	ZSB 25 0640	B6,4 DIN 125		Scheibe	Washer	Rondelle
26	ZNP 01 1000			Schmiernippel	Grease fitting	Graisseur
27	ZSR 12 0835	M8x35 DIN 912		Innensechskantschraube	Allen head screw	Vis six pans creux
28	ZSR 12 0630	M6x30 DIN 912		Innensechskantschraube	Allen head screw	Vis six pans creux
29	ZSR 12 0830	M8x30 DIN 912		Innensechskantschraube	Allen head screw	Vis six pans creux
	B4A 020 000			G. Querspindel M	Lead screw M	Vis transversale M
	B4B 020 000			G. Querspindel Ww	Lead screw Ww	Vis transversale Ww
30	B4A 020 010			Querspindel M	Lead screw M	Vis transversale M
	B4B 020 010			Querspindel Ww	Lead screw Ww	Vis transversale Ww
31	B4A 020 020			Querspindelträger	Lead screw mount	Support vis transversale
32	B2A 000 060			Skalenschild M	Plate M	Plaquette indicatrice M
	B2B 040 030			Skalenschild Ww	Plate Ww	Plaquette indicatrice Ww
33	B4A 020 030			Skalenring M	Micrometer collar M	Vernier M
	B4B 020 030			Skalenring Ww	Micrometer collar Ww	Vernier Ww
34	B2A 000 080			Bogenfeder	Spring	Ressort de pression
35	B4A 000 030			Handrad	Handwheel	Volant
36	B2A 000 100			Mutter	Nut	Ecrou
37	B2A 013 000			Gr. Kegelgriff	Handle	Manneton
38	ZFD 88 0337	3x3,7 DIN 6888		Scheibenfeder	Key	Clavette Woodruff
39	ZST 51 0806	M8x6 DIN 551		Gewindestift	Set screw	Vis réglage
40	ZNA 76 0144	1,4x4 DIN 1476		Kernnagel	Rivet	Rivet de fixation
41	ZSR 12 0816	M8x16 DIN 912		Innensechskantschraube	Allen head screw	Vis six pans creux

	B4A 050 000 B4B 050 000			G. Obersupport M G. Obersupport Ww	Compound M Compound Ww	Support superieur M Support superieur Ww
Pos	Ref.No.	DIN		BENENNUNG	DESCRIPTION	DESIGNATION
1	B4A 050 010			Obersupport	Compound	Support superieur
2	B2A 050 020			Oberplatte	Swivel base	Glissière supérieure
3	B2A 050 030			Einstelleiste	Gib	Lardon
4	B2A 050 041			Klemmring	Clamping ring	Bague de rotation
5	B2A 050 050			Skalenring	Micrometer collar	Vernier d'indexage
	B2A 050 060			Obermutter M	Lead screw nut M	Ecrou de vis chariot supérieur M
6	B2B 050 060			Obermutter Ww	Lead screw nut Ww	Ecrou de vis chariot supérieur Ww
7	B2A 050 070			Einstellschraube	Adjusting screw	Vis de réglage
8	B4A 050 080			Schraube	Screw	Axe du porte-outil
9	B2A 050 090			Nutenschraube	T-nut screw	Boulon tête carrée
10	B2A 050 100			Druckstift	Stud	Vis pour lardon
11	B2A 040 100			Sechskantmutter	Nut	Ecrou hexagonal
12	ZSR 61 0830	AM8x30 DIN 561		Sechskantschraube	Hexagon head screw	Boulon hexagonal
13	ZSR 84 0512	M5x12 DIN 84		Zylinderschraube	Flat head screw	Vis cylindriques
14	ZSR 84 0610	M6x10 DIN 84		Zylinderschraube	Flat head screw	Vis cylindriques
15	ZST 51 0410	M4x10 DIN 551		Gewindestift	Set screw	Vis réglage
16	ZMU 34 0400	M4 DIN 934		Sechskantmutter	Nut	Ecrou hexagonal
17	ZMU 34 0600	M6 DIN 934		Sechskantmutter	Nut	Ecrou hexagonal
18	ZHL 81 0212	2x12 DIN 1481		Spannhülse	Lock pin	Pion de centrage
19	ZHL 81 0312	3x12 DIN 1481		Spannhülse	Lock pin	Pion de centrage
20	B4A 050 11C			Spannklaue	Tool clamp	Bride de serrage de l'outil
21	B4A 050 120			Ballenscheibe	Washer	Rondelle sphérique
22	B4A 050 130			Druckfeder	Spring	Ressort de compression
	B4A 051 000			G. Oberspindel M	Lead screw M	Vis chariot supérieur M
	B4B 051 000			G. Oberspindel Ww	Lead screw Ww	Vis chariot supérieur Ww
23	B2A 051 010			Oberspindel M	Lead screw M	Vis chariot supérieur M
	B2B 051 010			Oberspindel Ww	Lead screw Ww	Vis chariot supérieur Ww
24	B2A 051 020			Oberspindelträger M	Lead screw mount M	Palier vis supérieur M
	B2A 020 030			Oberspindelträger Ww	Lead screw mount Ww	Palier vis supérieur Ww
25	B2B 020 030			Skalenring M	Micrometer collar M	Vernier M
26	B4A 051 010			Skalenring Ww	Micrometer collar Ww	Vernier Ww
27	B2A 051 040			Handrad	Handwheel	Volant
28	ZFD 88 0337	3x3,7 DIN 6888		Kegelgriff	Handle	Manneton
29	B2A 000 080			Scheibenfeder	Key	Clavette Woodruff
30	B2A 000 100			Bogenfeder	Spring	Ressort de pression
31	ZST 51 0806	M8x6 DIN 551		Mutter	Nut	Ecrou à 2 plats
32	ZHL 81 0308	3x8 DIN 1481		Gewindestift	Set screw	Vis réglage
				Spannhülse	Lock pin	Pion de centrage

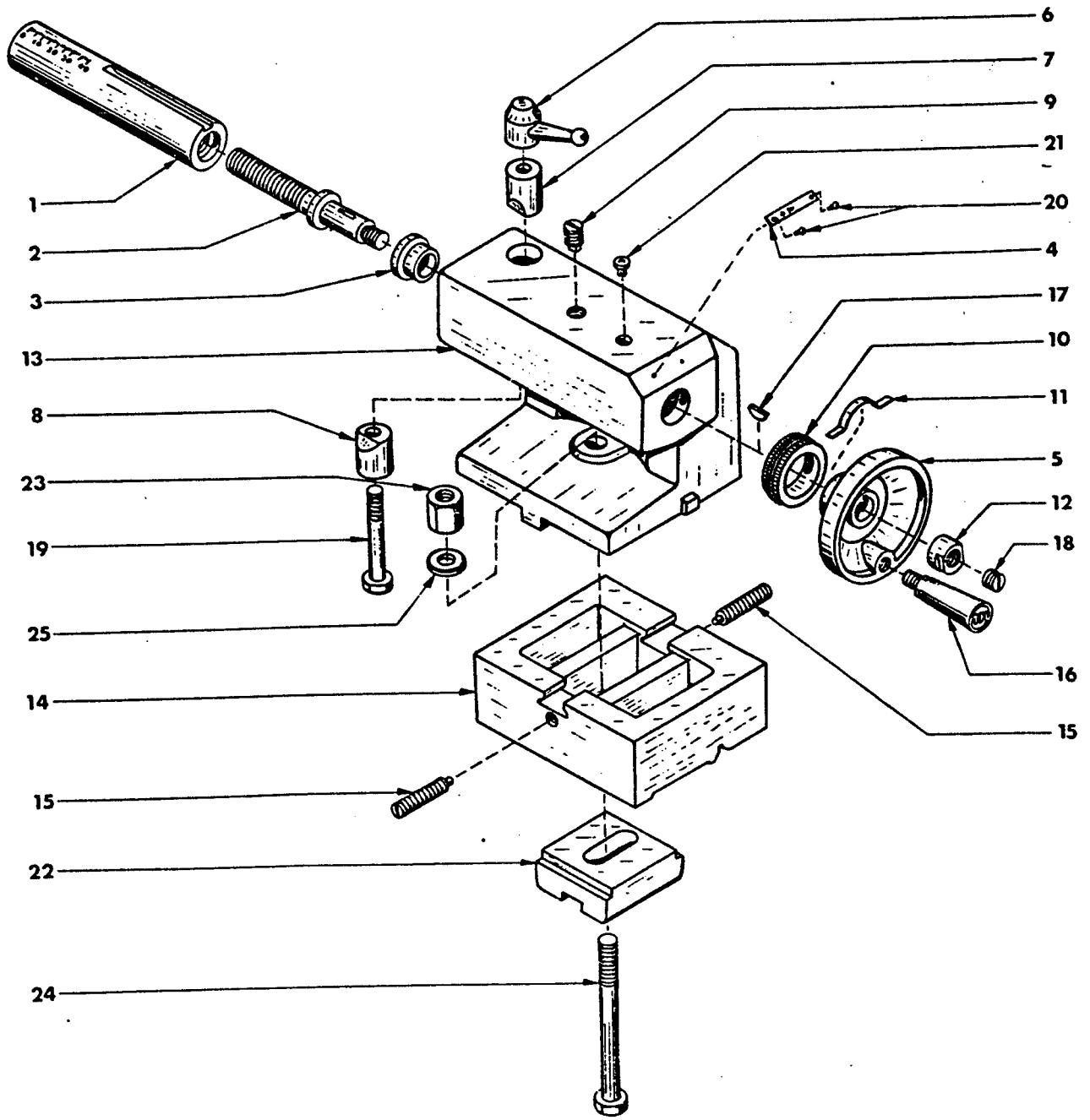

Copyright © 1964 by General Electric Company

	B4A 040 000 B4B 040 000			G. Reitstock M G. Reitstock Ww	Tailstock M Tailstock Ww	Contre pointe M Contre pointe Ww
Pos	Ref.No.	DIN		BENENNUNG	DESCRIPTION	DESIGNATION
1	B2A 040 010			Reitstockpinole M	Tailstock ram M	Fourreau de contre pointe M
1	B2B 040 010			Reitstockpinole Ww	Tailstock ram Ww	Fourreau de contre pointe Ww
2	B2A 040 020			Triebsschraube M	Lead screw M	Vis de commande M
2	B2B 040 020			Triebsschraube Ww	Lead screw Ww	Vis de commande Ww
3	B2A 040 030			Bundbüchse	Bushing	Bague
4	B2A 000 060			Skalenschild M	Plate M	Plaquette indicatrice M
4	B2B 040 030			Skalenschild Ww	Plate Ww	Plaquette indicatrice Ww
5	B4A 040 011			Handrad	Handwheel	Volant
6	B2A 040 050			Knebelgriff	Lever	Poignée de blocage
7	B2A 040 060			Klemmbacke	Clamp	1/2 noix superieur de blocage
8	B2A 040 070			Klemmstück	Binding piece	1/2 noix superieur de blocage
9	B2A 040 080			Führungsschraube	Guide pin	Vis de guidage
10	B2A 000 090			Skalenring M	Micrometer collar M	Vernier M
10	B2B 020 030			Skalenring Ww	Micrometer collar Ww	Vernier Ww
11	B2A 000 080			Bogenfeder	Feed spring	Ressort réglage
12	B2A 000 100			Mutter	Nut	Ecrou à 2 plats
13	B4A 041 000			G. Reitstockplatte	Tailstock base	Glissière support contre pointe
14	B2A 041 010			Reitstock	Tailstock	Contre pointe
14	B4A 041 020	525.- exkl.		Reitstockplatte	Tailstock base	Glissière support contre pointe
15	ZST 17 0630	M6x30 DIN 417		Gewindestift	Set screw	Vis réglage
16	B2A 013 000			G. Kegelgriff	Handle	Manneton
17	ZFD 88 0337	3x3,7 DIN 6888		Scheibenfeder	Key	Clavette Woodruff
18	ZST 51 0806	M8x6 DIN 551		Gewindestift	Set screw	Vis réglage
19	ZSR 31 0650	M6x50 DIN 931		Sechskantschraube	Hexagonal screw	Vis hexagonale
20	ZNA 76 0144	1,4x4 DIN 1476		Kerbnagel	Rivet	Rivet de fixation
21	ZNP 01 1000			Schmiernippel	Grease fitting	Graisseur
22	B2A 040 090			Klemmplatte	Clamping plate	Plaque de serrage inférieure
23	B2A 040 100			Sechskantmutter	Nut	Ecrou hexagonal
24	ZSR 31 0890	M8x90 DIN 931		Sechskantschraube	Hexagonal screw	Vis hexagonale
25	ZSB 25 0840	B8,4 DIN 125		Scheibe	Washer	Rondelle

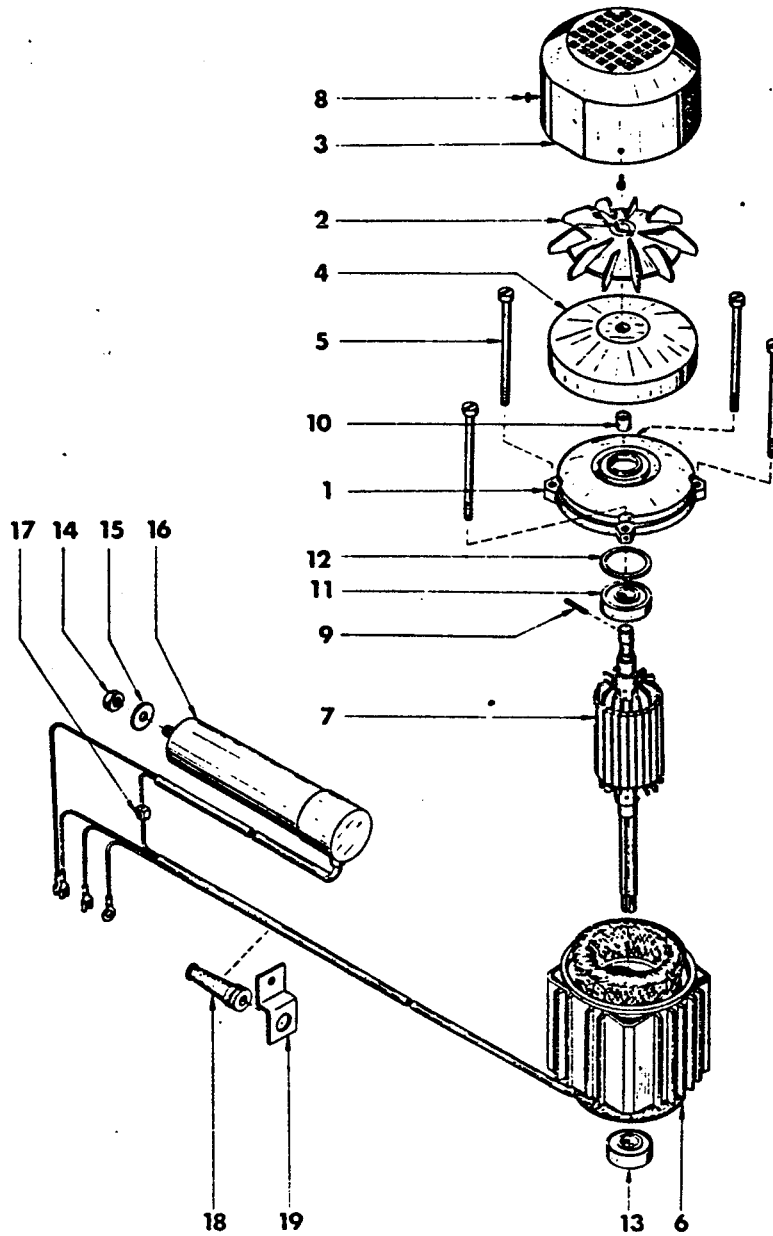

4+10 Entfällt bei Drehstromausführung — ersetzt durch Distanzhülse E2A 110 010  
 Not applicable with three-phase make — replaced by spacer sleeve E2A 110 010  
 Ne s'applique pas en version triphasé — remplacée par la douille d'écartement E2A 110 010

\* Bei Bestellung bitte Spannung und Frequenz angeben.  
 In your orders please indicate voltage and frequency.  
 A la commande spécifier le voltage et la fréquence du moteur.



	VERTIKALE			Motor F F D	Motor F F D	Moteur F F D
Pos	Ref.No.	DIN		BENENNUNG	DESCRIPTION	DESIGNATION
1	E1A 100 050			Lagerschild	Bearing bracket	Flasque superieur moteur
2	E1A 100 030			Lüfterflügel	Fan	Ventilateur
3	E1A 100 020			Lüfterhaube	End shield	Carter du ventilateur
4	E1A 100 040			Schwungrad	Flywheel	Volant
5	E1A 100 060			Schraube	Screw	Vis
6				Stator *	Stator*	Stator*
7	ZMR 15 3200			Rotor *	Rotor*	Rotor*
8	ZSR 84 0304	M3x4 DIN 84		Zyl. Schraube	Flat head screw	Vis cylindriques
9	ZHL 81 0322	3x22 DIN 1481		Spannhülse	Lock pin	Manchon de goupille
10	ZRG 30 1010	BN 10x10		Toleranzring	Locking collar	Bague de tolerance
11	ZLG 62 0102	6201-2Z		Kugellager	Ball bearing	Roulement a billes
12	ZSB 00 6201			Scheibe	Washer	Rondelle
13	ZEL 02 0001	0,5-1 MM2		Flachstecker	Spade terminal	Fiche plate
14	ZMU 34 0800	M8 DIN 934		Mutter	Nut	Ecrou
15	E1A 100 010			Scheibe	Washer	Rondelle
	ZKO 15 3853			Kondensator 8µF 300V	Condenser 8µF 300V	Condensateur 8µF 300V
16	ZKO 15 3520			Kondensator 20µF 330V	Condenser 20µF 330V	Condensateur 20µF 330V
17	ZEL 01 000	EDK 1		Dosenklemme	Cable connector	Connector unipolaire
18	ZEL 70 0080	T-8		Knickschutztülle	Protective coating	Passafil caoutchouc
19	E2A 100 010			Winkelblech	Angle plate	Corniere
20	ZEL 70 0080	T-8		Knickschutztülle	Protective coating	Passafil caoutchouc

				Motor Garvens	Motor Garvens	Moteur Garvens
Pos	Ref.No.	DIN		BENENNUNG	DESCRIPTION	DESIGNATION
1	E1A 100 050			Lagerschild	Bearing bracket	Flasque superieur moteur
2	E1A 100 030			Lüfterflügel	Fan	Ventilateur
3	E1A 100 020			Lüfterhaube	End shield	Carter du ventilateur
4	E1A 100 040			Schwungrad	Flywheel	Volant
5	E1A 100 061			Schraube	Screw	Vis
6				Stator *	Stator*	Stator*
7	ZMR 16 3002			Rotor *	Rotor*	Rotor*
8	ZSR 84 0304	M3x4 DIN 84		Zyl. Schraube	Flat head screw	Vis cylindriques
9	ZHL 81 0322	3x22 DIN 1481		Spannhülse	Lock pin	Manchon de goupille
10	ZRG 30 1010	BN 10x10		Toleranzring	Locking collar	Bague de tolerance
11	ZLG 62 0102	6201-2Z		Kugellager	Ball bearing	Roulement a billes
12	ZSB 00 6201			Scheibe	Washer	Rondelle
13	ZEL 02 0001	0,5 - 1 MM2		Flachstecker	Spade terminal	Fiche plate
14	ZMU 34 0800	M8 DIN 934		Mutter	Nut	Ecrou
15	E1A 100 010			Scheibe	Washer	Rondelle
16	ZKO 15 3520			Kondensator 20µF 330V	Condenser 20µF 330V	Condensateur 20µF 330V
17	ZEL 01 0001	EDK1		Dosenklemme	Cable connector	Connector unipolaire
18	ZEL 70 0080	T-8		Knickschutztülle	Protective coating	Passafil caoutchouc
19	E2A 100 010			Winkelblech	Angle plate	Corniere
20	ZEL 70 0080	T-8		Knickschutztülle	Protective coating	Passafil caoutchouc

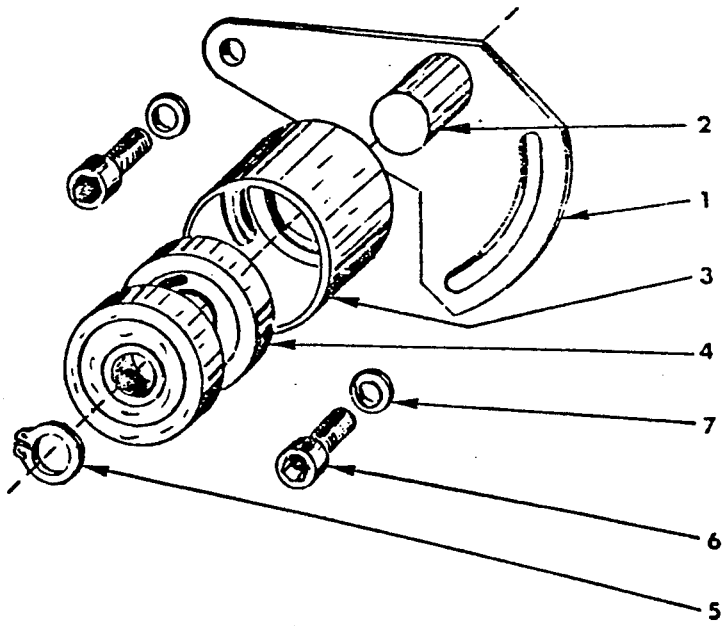
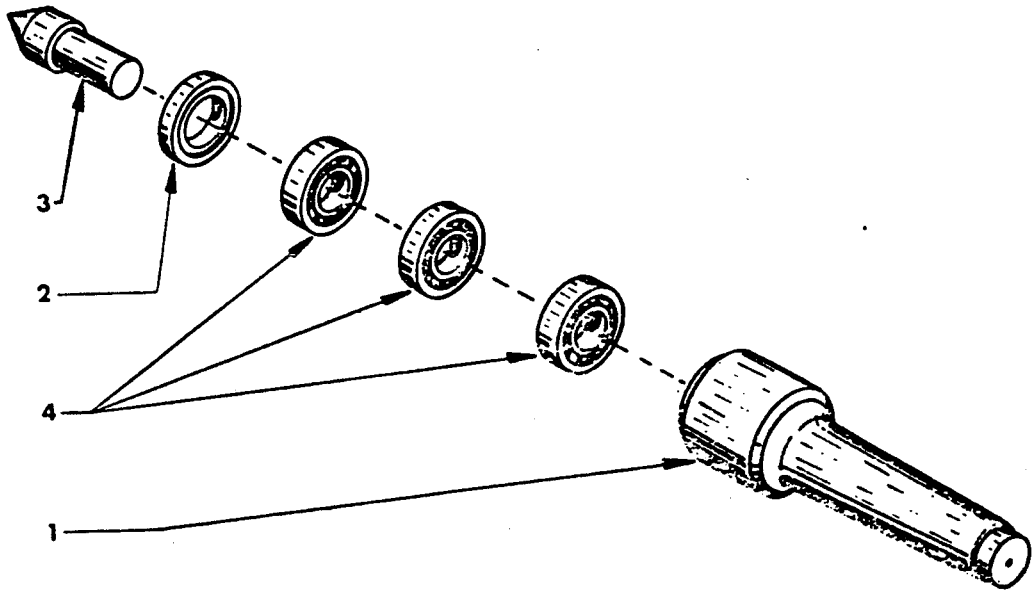

				G. Rollkörper	Revolving center	Pointe tournante
Pos	Ref.No.	DIN		BENENNUNG	DESCRIPTION	DESIGNATION
1	B2Z 260 010			Körper	Tapered shank	Corps
2	B2Z 260 020			Abdeckring	Cover	Couvercle
3	B2Z 260 030			Körner	Center	Pointe
4	ZLG 06 0800	608 EL8		Rillenkugellager	Ball bearing	Roulement à billes

	B2A 180 000			G. Riemenspanner	Tensioning roller	Rouleau tendeur
Pos	Ref.No.	DIN		BENENNUNG	DESCRIPTION	DESIGNATION
1	B2A 180 011			Spannblech	Plate	Bras de tendeur
2	B2A 180 020			Lagerbolzen	Journal	Support de palier
3	B2A 180 030			Rolle	Roller	Rouleau
4	ZLG 06 0801	608 - Z		Rillenkugellager	Ball bearing	Roulement à billes (à gorges)
5	ZRG 71 0808	8x0,8 DIN 471		Sicherungsring	Circlip	Circlip
6	ZSR 12 0616	M6x16 DIN 912		Innensechskantschraube	Allen head screw	Vis 6 pans creux
7	ZSB 25 0640	B6,4 DIN 125		Scheibe	Washer	Rondelle

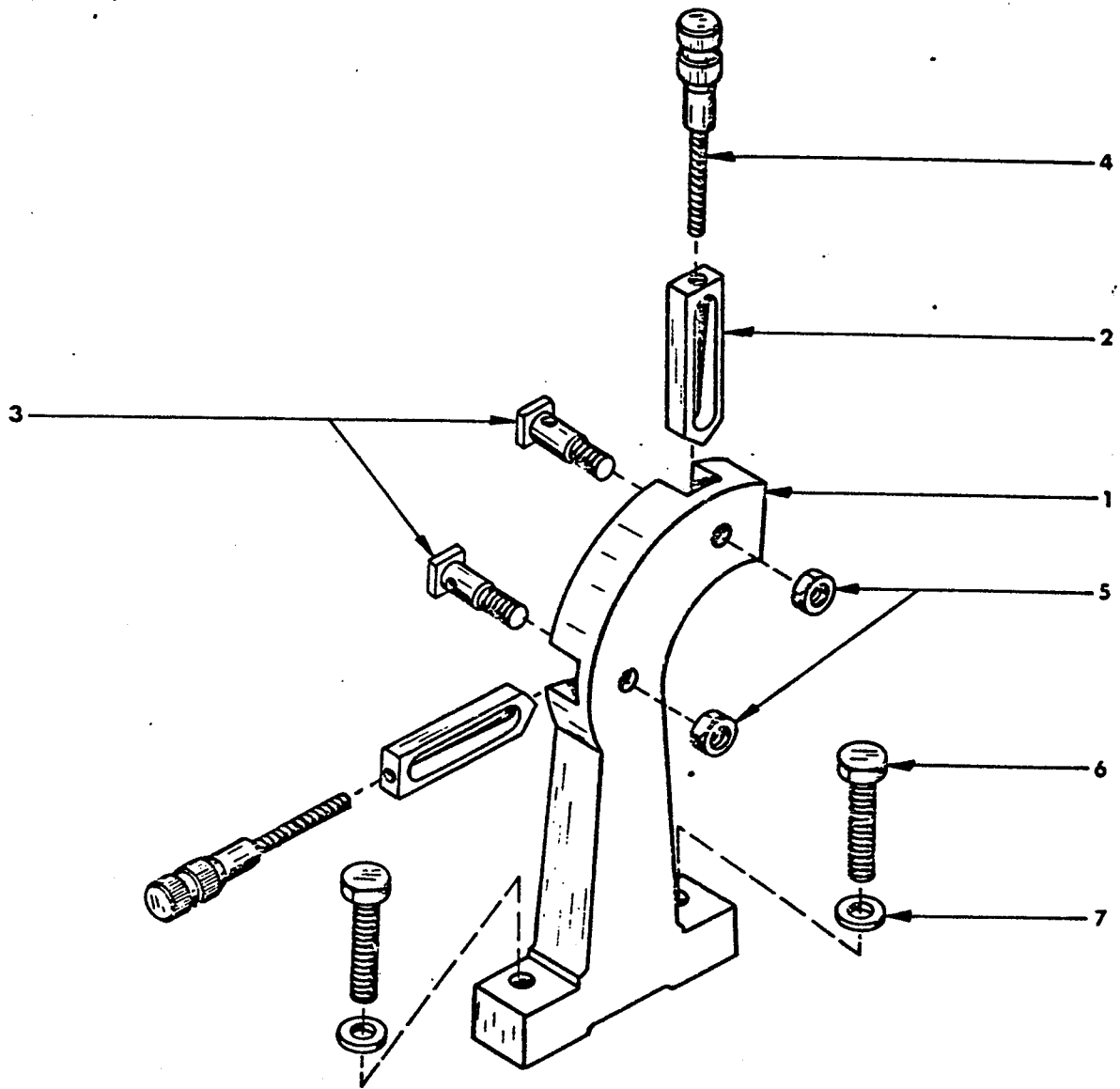

Pos	Ref.No.	DIN	G. Lauflünette	Follower rest	Lunette a suivre
			BENENNUNG	DESCRIPTION	DESIGNATION
1	B4Z 230 010		Laufflünette	Housing	Corps
2	B2Z 230 020		Gleitbacke	Jaw	Touche
3	B2Z 230 030		Nutschraube	Screw	Vis
4	B2Z 230 040		Stellschraube	Thumb screw	Vis moletée
5	ZMU 34 0800	M8 DIN 934	Sechskantmutter	Nut	Ecrou hexagonal
6	ZSR 33 0625	M6x25 DIN 933	Sechskantschraube	Hexagonal screw	Vis hexagonale
7	ZSB 25 0640	B6,4 DIN 125	Scheibe	Washer	Rondelle

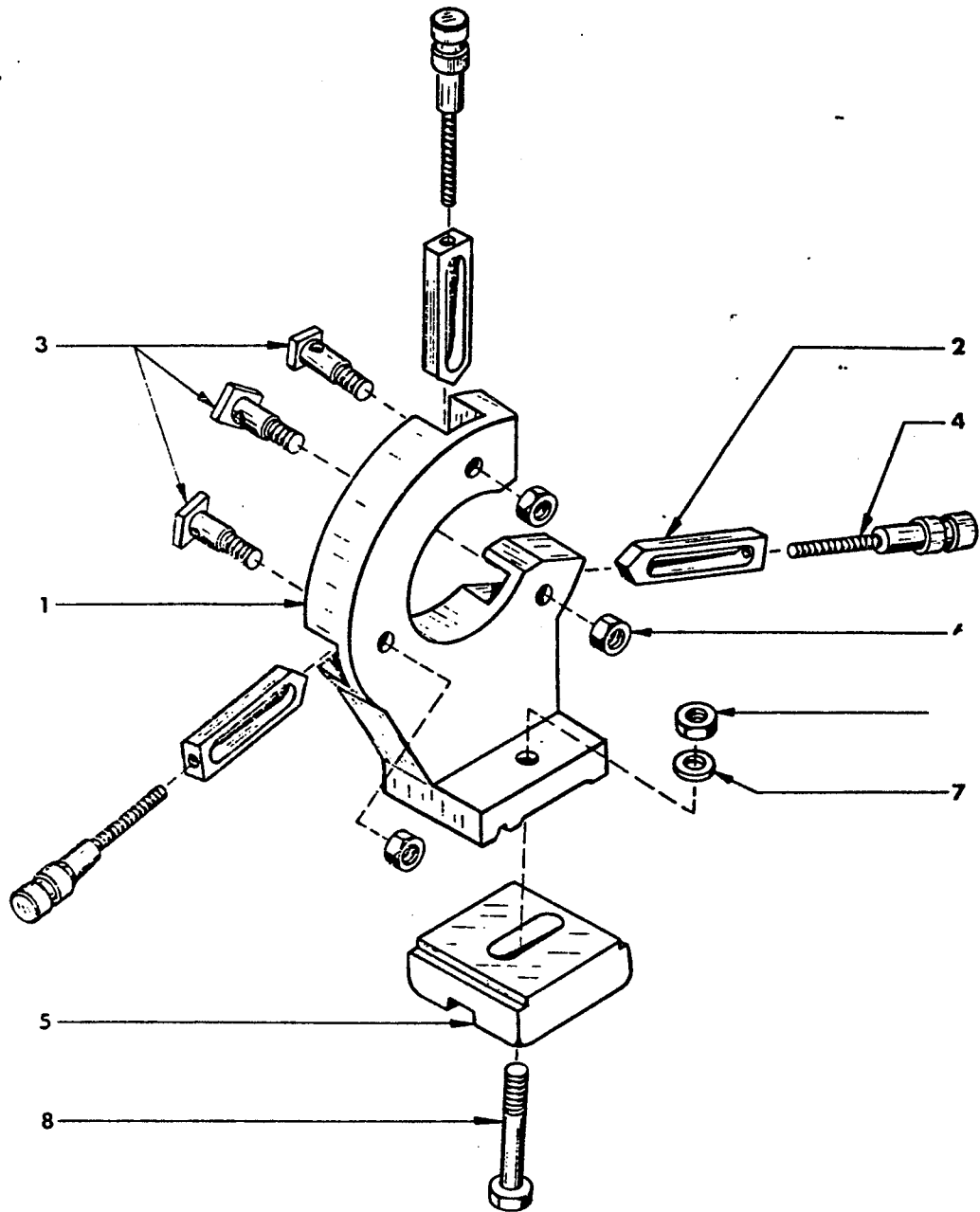

Pos	Ref.No.	DIN	G. Stehlünette	Steady rest	Lunette fix
Pos	Ref.No.	DIN	BENENNUNG	DESCRIPTION	DESIGNATION
1	B4Z 240 010		Stehlünette	Housing	Corps
2	B2Z 230 020		Gleitbacke	Jaw	Touche
3	B2Z 230 030		Nutschraube	Screw	Vis
4	B2Z 230 040		Stellschraube	Thumb screw	Vis moletée
5	B2A 040 090		Klemmplatte	Clamping plate	Plaque
6	ZMU 34 0800	M8 DIN 934	Sechskantmutter	Nut	Ecrou
7	ZSB 25 0840	B8,4 DIN 125	Scheibe	Washer	Rondelle
8	ZSR 31 0850	M8x50 DIN 931	Sechskantschraube	Hexagonal screw	Vis hexagonal

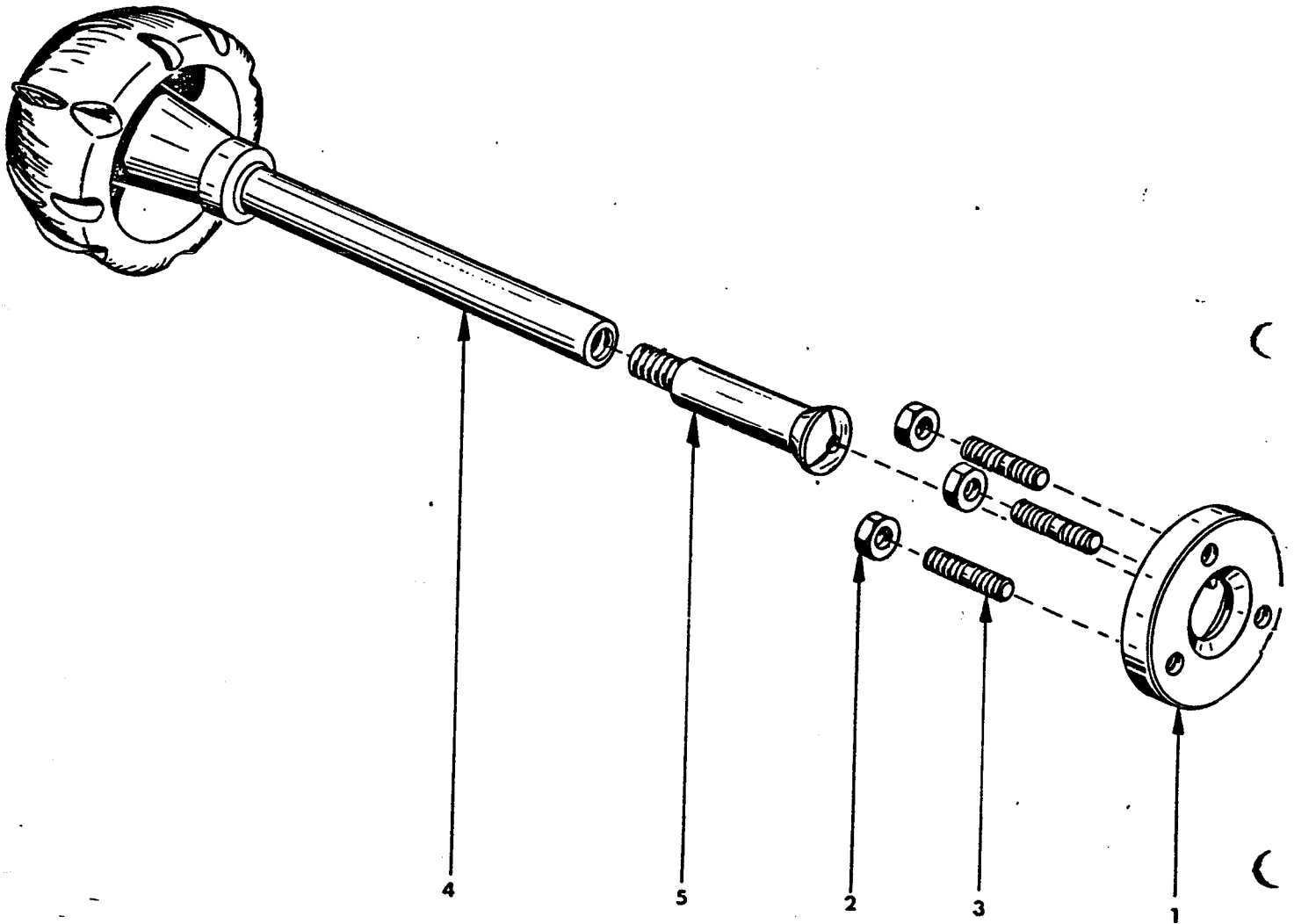

Pos.	Ref.No.	DIN	G. Spannzangenhalter	Collet attachment	Dispositif de serrage par pinces
			BENENNUNG	DESCRIPTION	DESIGNATION
1	84Z 041 000 84Z 041 010		G. Zangenhalter Zangenhalter	Flange Flange	Tirant Tirant
2	ZMU 34 0800		Sechskantmutter	Nut	Ecrou hexagonal
3	ZSR 39 0820		Stiftschraube	Stud	Goujon filetée
4	82Z 041 000		G. Anzugs spindle	Draw bar	Tirant
5	ZSZ_00 0000		Zange	Collet	Pince

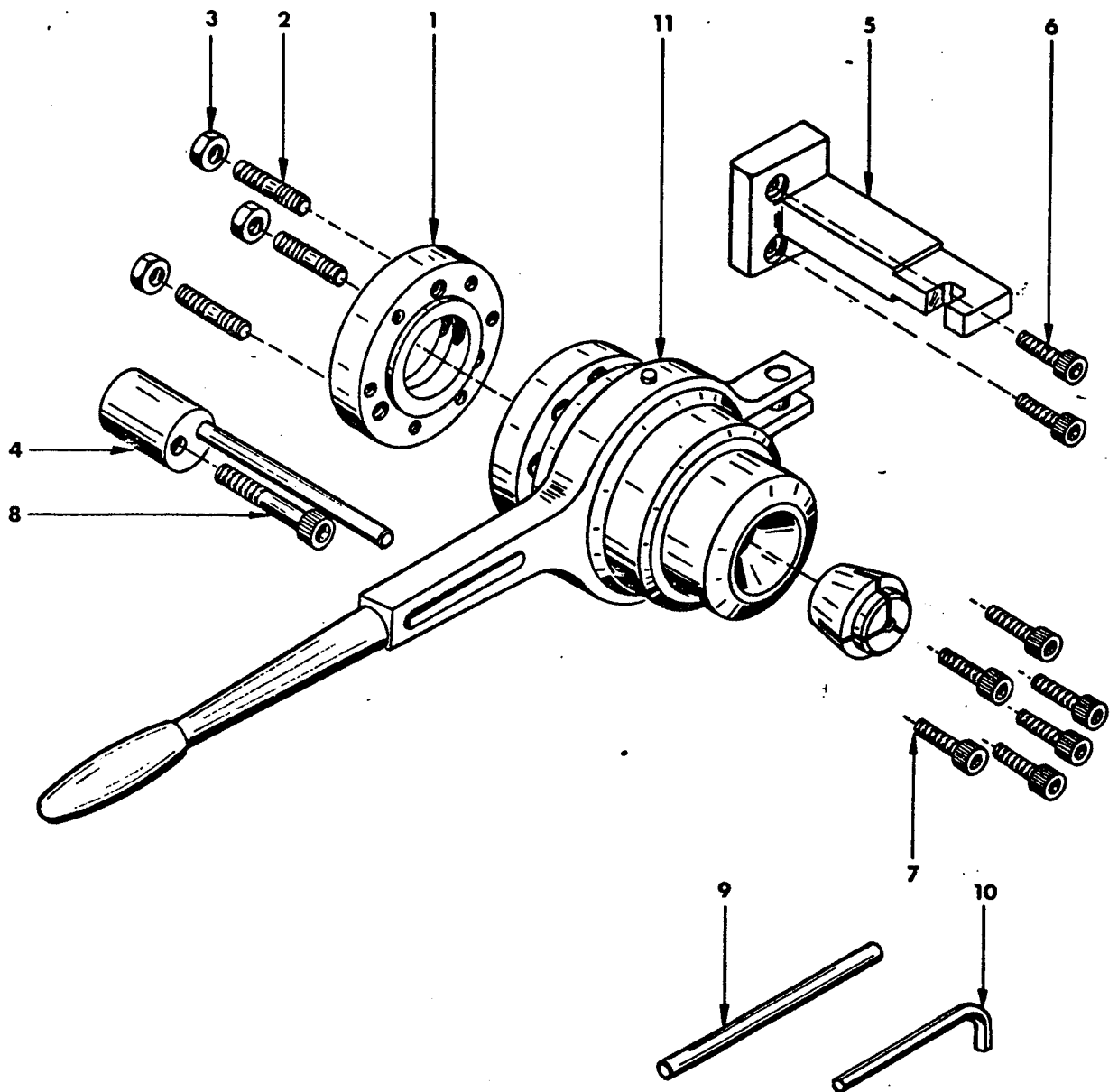

Pos	Ref.No.	DIN	BENENNUNG	DESCRIPTION	DESIGNATION
			G. Schnellspannfutter	Quick action collet chuck	Mandrin a serrage rapide
1	B4Z 071 000 B4Z 071 010		G. Flansch Flansch	Backplate Backplate	Plateau Plateau
2	ZSR 39 0820	M8x20 DIN 939	Stiftschraube	Stud	Goujon fileté
3	ZMU 34 0800	M8 DIN 934	Sechskantmutter	Nut	Ecrou hexagonal
4	B2Z 072 000		G. Auflagebolzen	Bolt	Boulon
5	B4Z 070 010		Stütze	Braket	Lünette
6	ZSR 12 0620	M6x20 DIN 912	Innensechskantschraube	Allen head screw	Vis six pans creux
7	ZSR 12 0616	M6x16 DIN 912	Innensechskantschraube	Allen head scre	Vis six pans creux
8	ZSR 12 0845	M8x45 DIN 912	Innensechskantschraube	Allen head screw	Vis six pans creux
9	ZST 11 0710	6M11x100 DIN 7	Zylinderstift	Pin	Axa carter
10	ZWZ 11 0600		Sechskantstiftschlüssel	Hexagonal key	Ci6 à six pans
11	SSF 20Z		Schnellspannfutter	Quick action collet chuck	Mandrin à serrage rapide

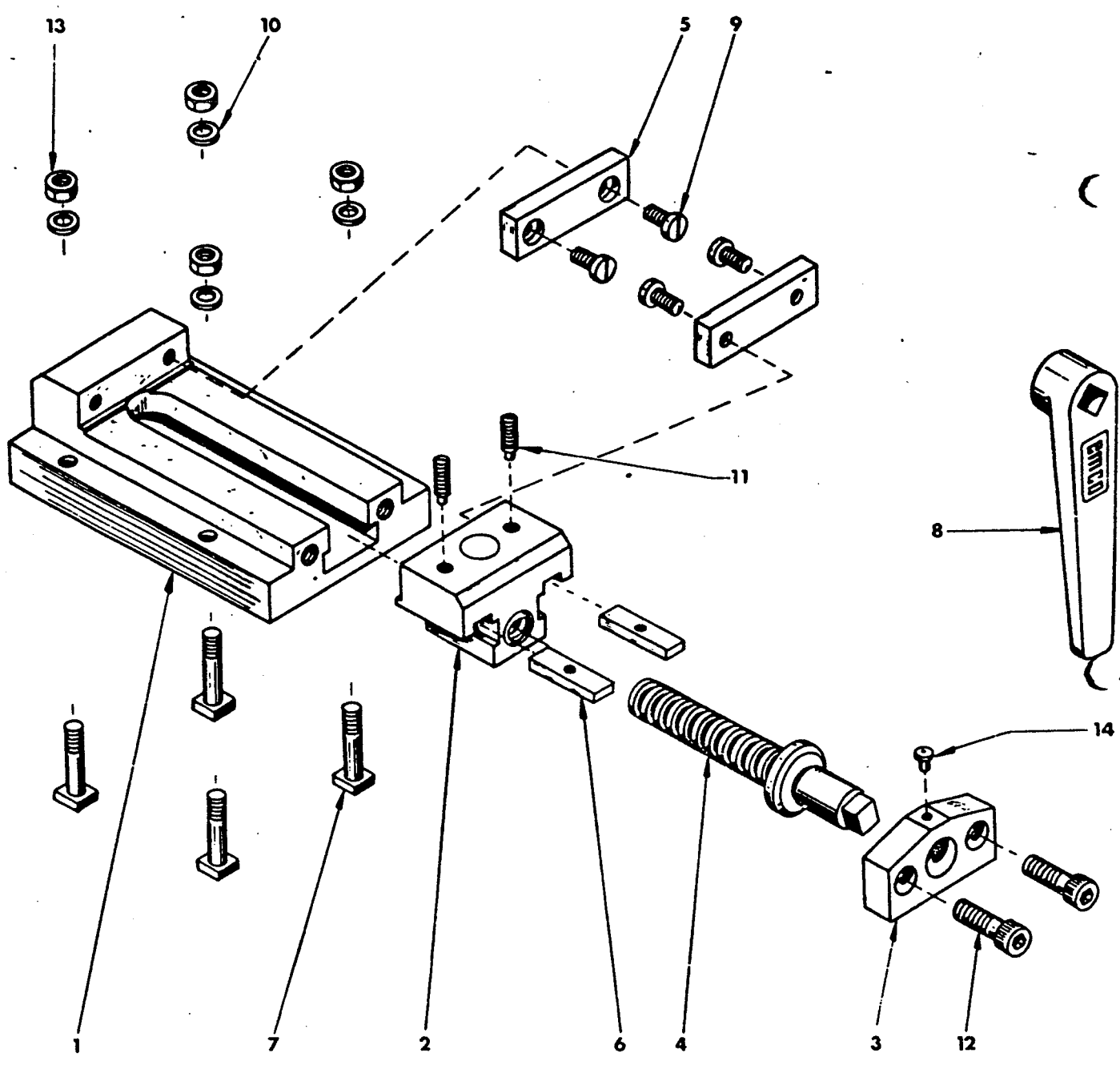



				G. Maschinenschraub- stock	Clamping vice	Etau
Pos	Ref.No.	DIN		BENENNUNG	DESCRIPTION	DESIGNATION
1	B2Z 310 010			Körper	Housing	Corps
2	B2Z 310 020			Backe	Jaw	Machoire
3	B2Z 310 030			Spindelträger	Lead screw mount	Support de vis
4	B2Z 310 040			Spindel	Lead screw	Vis de serrage
5	B2Z 310 050			Aufsatzbacke	Jaw	Support de machoir
6	B2Z 310 060			Einstelleiste	Gib	Filet supérieur
7	B2Z 310 070			Nutenschraube	T-nut	Glissière
8	B2Z 310 080			Schlüssel	Wrench	Cle carrée
9	ZSR 84 0512	M5x12 DIN 84		Zyl. Schraube	Flat head screw	Vis cylindriques
10	ZSB 25 0640	B6,4 DIN 125		Scheibe	Washer	Rondelle
11	ZST 17 0515	M5x15 DIN 417		Gewindestift	Set screw	Tige filetée
12	ZSR 12 0825	M8x25 DIN 912		Innensechskantschraube	Allen head screw	Vis six pans creux
13	ZMU 34 0600	M6 DIN 34		Mutter	Nut	Errou
14	ZNP 01 1000			Schmiernippel	Grease fitting	Graisseur

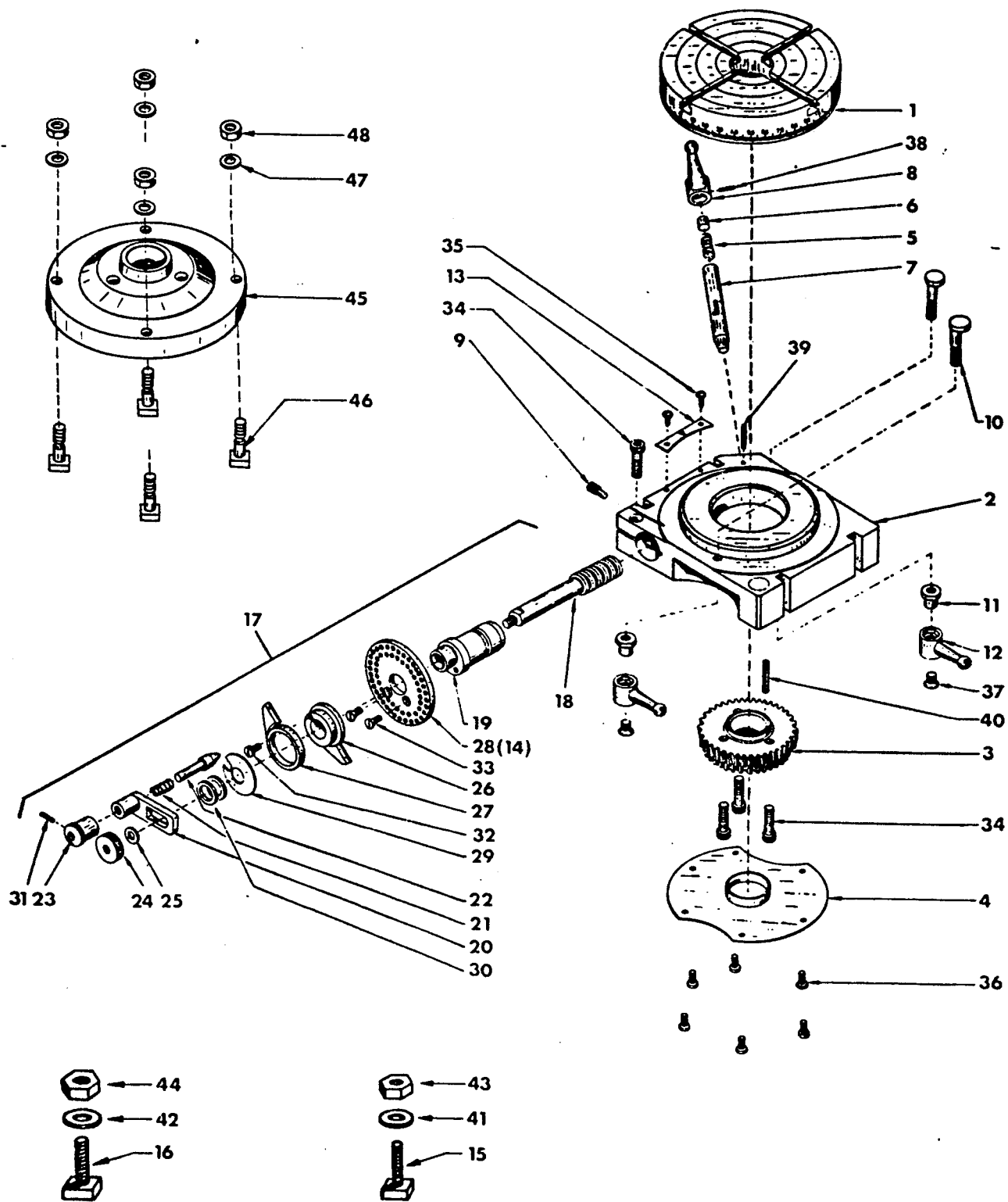

				G. Teilapparat	Dividing head	Appareil diviseur
Pos	Ref.No.	DIN		BENENNUNG	DESCRIPTION	DESIGNATION
1	B2Z 320 010			Rundtisch	Table	Table
2	B2Z 320 020			Gehäuse	Housing	Corps
3	B2Z 320 030			Teilrad	Table flange	Broche diviseur
4	B2Z 320 040			Deckblech	Cover mount	Couvercle
5	B2Z 320 050			Druckfeder	Compression spring	Ressort à pression
6	B2Z 320 060			Druckbolzen	Bolt	Boulon
7	B2Z 320 070			Index	Locking pin	Index
8	B2Z 320 080			Knebelgriff	Lever	Levier
9	B2Z 320 090			Anschlagschraube	Bushing	Douille
10	B2Z 320 100			Klemmschraube	Locking bolt	Vis de blocage
11	B2Z 320 110			Mutter	Nut	Ecrou
12	B2Z 320 120			Knebelgriff	Lever	Levier
13	B2Z 320 130			Zeiger	Guide	Indicateur
	B2Z 320 140			Lochscheibe 33-36-39	Indexing plate	Disque à trous
14	B2Z 320 150			Lochscheibe 38-40	Indexing plate	Disque à trous
15	B2Z 320 160			Nutenschraube	T-Nut	Glissière
16	B2Z 320 170			Nutenschraube	T-Nut	Glissière
17	B2Z 321 000			Gr. Schnecke	Worm shaft	Vis sans fin
18	B2Z 321 010			Schnecke	Worm shaft	Vis sans fin
19	B2Z 321 020			Exzenter	Assembly arbor	Excentrique
20	B2Z 321 030			Kurbel	Crank	Manivelle
21	B2Z 321 040			Druckfeder	Compression spring	Ressort à pression
22	B2Z 321 050			Absteckbolzen	Bolt	Boulon
23	B2Z 321 060			Hülse	Sleeve	Gousse
24	B2Z 321 070			Rändelmutter	Knurled nut	Ecrou molarée
25	B2Z 321 080			Scheibe	Plate	Poulie
26	B2Z 321 090			Schere rechts	Section arm r. h.	Lyre droite
27	B2Z 321 100			Schere links	Section arm l. h.	Lyre gauche
28	B2Z 321 120			Lochscheibe	Indexing plate	Disque à trous
29	B2Z 321 130			Tellerfeder	Spring washer	Ressort hélicoïdal
30	B2Z 321 150			Scheibe	Plate	Poulie
31	ZHL 81 0212	2x12 DIN 1481		Spannhülse	Pin	Tige de serrage
32	ZSR 85 0406	AM4x6 DIN 85		Zylinderschraube	Flat head screw	Vis cylindriques
33	ZSR 63 0410	M4x10 DIN 963		Senkschraube	Flat head screw	Vis de sûreté
34	ZSR 12 0625	M6x25 DIN 912		Innensechskantschraube	Allen head screw	Vis six pans creux
35	ZSR 84 0304	M3x4 DIN 84		Zylinderschraube	Flat head screw	Vis cylindriques
36	ZSR 84 0406	M4x6 DIN 84		Zylinderschraube	Flat head screw	Vis cylindriques
37	ZSR 63 0608	M6x8 DIN 963		Senkschraube	Flat head screw	Vis de sûreté
38	ZHL 81 0214	2x14 DIN 1481		Spannhülse	Pin	Tige de serrage
39	ZHL 81 0322	3x22 DIN 1481		Spannhülse	Pin	Tige de serrage
40	ZHL 81 0530	5x30 DIN 1481		Spannhülse	Pin	Tige de serrage
41	ZSB 25 0640	B6,4 DIN 125		Scheibe	Washer	Rondelle
42	ZSB 25 0840	B8,4 DIN 125		Scheibe	Plate	Poulie
43	ZMU 34 0600	M6 DIN 934		Mutter	Nut	Ecrou
44	ZMU 34 0800	M8 DIN 934		Mutter	Nut	Ecrou
45	B4Z 170 000			G. Zwischenflansch	Backplate	Plateau
46	B4Z 170 010			Zwischenflansch	Backplate	Plateau
47	ZSB 25 0640	B6,4 DIN 125		Nutenschraube	T-Nut	Glissière
48	ZMU 34 0600	M6 DIN 934		Scheibe	Washer	Rondelle
				Sechskantmutter	Nut	Ecrou hexagonal

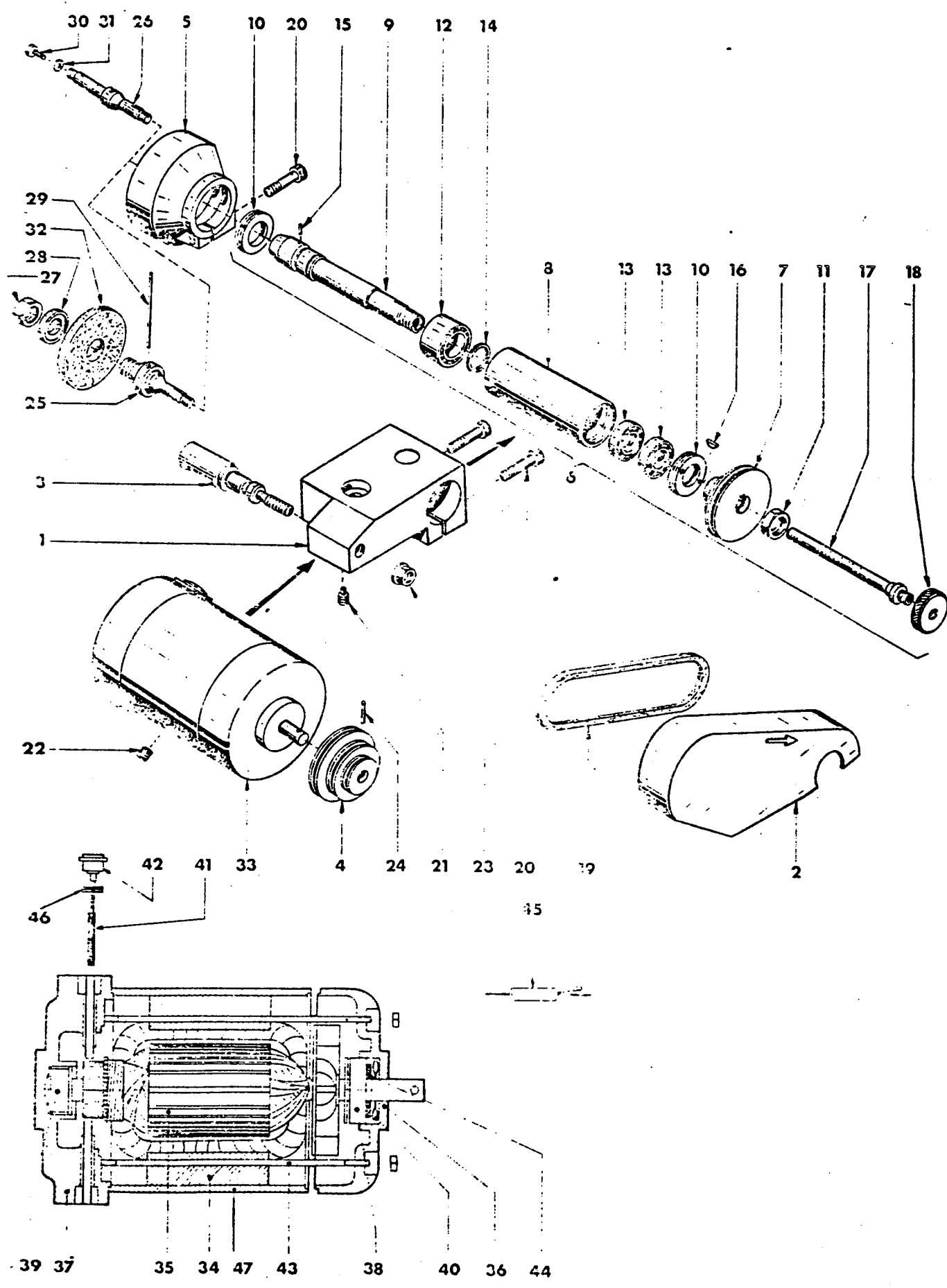

				Supportschleifapparat	Tool post grinder	Dispositif d'affutage sur support
Pos	Ref.No.	DIN		BENENNUNG	DESCRIPTION	DESIGNATION
1	SOB 000 010			Körper	Housing	Corps
2	SOA 000 020			Riemenschutz	Cover	Carter protecteur
3	SOA 000 030			Motorbolzen	Bolt	Tasseau
4	SOA 000 040			Riemenscheibe	Pulley	Poulie
5	SOA 000 070			Scheibenschutz	Guard	Capot de protection des meules
6	SOA 010 000			G. Schleifpinole	Quill	Fourreau porte pince
7	SOA 010 010			Riemenscheibe	Pulley	Poulie
8	A2Z 280 010			Spannzangenpinole	Quill	Fourreau porte pince
9	A2Z 280 020			Spindel	Tapered arbor	Broche
10	A2Z 280 030			Verschraubung	Screw joint	Fermeture à vis
11	A2A 040 060			Mutter	Nut	Ecrou
12	ZLG 80 4903	NA4903/C152 NA		Nadellager	Needle bearing	Roulement à aiguilles
13	ZLG 00 1307	E 13 K7		Kugellager	Ball bearing	Roulement à billes
14	ZRG 21 0170	WR 17		Sprengring	Spring washer	Ressort helicoidal
15	ZST 06 0156	1,5M6x6 DIN 7		Zylinderstift	Pin	Tige de serrage
16	ZFD 88 0226	2x2,6 DIN 6888		Scheibensfeder	Key	Ressort-spirale
17	A2Z 281 000			G. Anzugs spindle	Draw bar	Tuyau de serrage
18	A2Z 280 050			Zugrohr	Draw bar	Tuyau de serrage
19	A2Z 280 060			Spannrad	Draw bar wheel	Volant de serrage
20	ZRM 05 0352	352x5x3		Keilriemen	V-belt	Courroie trapézoïdale
21	ZSR 12 0630	M6x30 DIN 912		Innensechskantschraube	Allen head screw	Vis six pans creux
22	ZST 17 0612	M6x12 DIN 417		Gewindestift	Set screw	Vis
23	ZST 16 0808	AM8x8 DIN 916		Gewindestift	Set screw	Vis
24	ZMU 31 0800	M8 DIN 6331		Sechskantmutter	Nut	Ecrou hexagonal
25	ZHL 81 0220	2x20 DIN 1481		Spannhülse	Pin	Tige de serrage
26	SOA 000 050			Dorn	Tapered arbor	Arbre
27	SOA 000 060			Spindel	Tapered arbor	Broche
28	A2A 040 060			Mutter	Nut	Ecrou
29	A2Z 410 050			Gegenscheibe	Washer	Contre plateau
30	ZSR 84 0310	M3x10 DIN 84		Zylinderstift	Pin	Tige de serrage
31	ZSB 25 0320	A3,2 DIN 125		Zylinderschraube	Flat head screw	Vis de blocage
32	ZWZ 55 0016			Scheibe	Washer	Rondelle
33	ZMO 50 0			Schleifscheibe	Grinding wheel	Meule
34	ZME 15 1			Motor	Motor	Moteur
35	ZME 15 0			Stator	Stator	Stator
36	ZME 15 0004			Rotor	Rotor	Rotor
37	ZME 15 0005			Lagerschild	Bearing end plate	Flasquet-palier
38	ZME 15 0005	6200		Lagerschild	Bearing end plate	Flasquet-palier
39	ZLG 62 0000	608 EL 8		Rillenkugellager	Ball bearing	Roulement à billes
40	ZLG 06 0800			Rillenkugellager	Ball bearing	Roulement à billes
41	ZME 15 0008			Ausgleichscheibe	Washer	Entretoise
42	ZME 15 0001			Kohlebürste	Brush	Charbon
43	ZME 15 0010			Kohlenhalter-Kappe	Brush cap	Capuchon charbon
44	ZME 15 0009			Schraube	Clamping screw	Boulon-tirant
45	ZME 15 0007			Filz	Felt washer	Feutre
46	ZME 15 0002			Kondensator	Condensator	Condensateur
47	ZME 15 0003			Dichtung f. Kappe	Packing	Joint d'étanchéité
				Statorgehäuse	Casing of Stator	Carter du stator

\*) Bei Bestellung bitte Spannung angeben.

In your orders please indicate voltage.

-A la commande spécifier la voltage

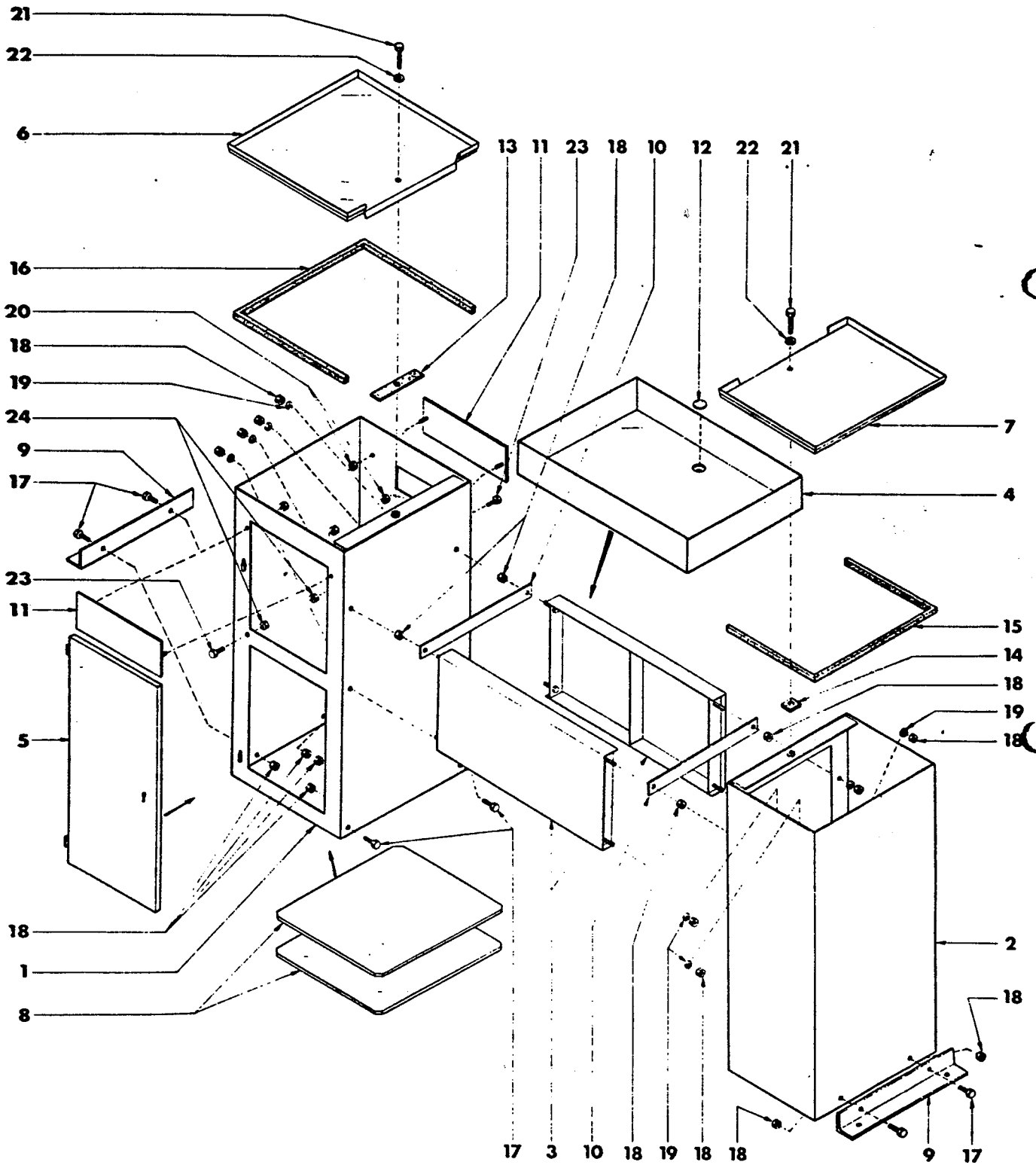

				G. Maschinenständer	Machine stand	Montant
Pos	Ref.No.	DIN		BENENNUNG	DESCRIPTION	DESIGNATION
	B2Z 360 010			Linker Ständerfuß 8.4	Table leg left 8.4	Pied gauche 8.4
1	C4Z 220 010			Linker Ständerfuß 8.6	Table leg left 8.6	Pied gauche 8.6
	B2Z 360 020			Rechter Ständerfuß 8.4	Table leg right 8.4	Pied droit 8.4
2	C4Z 220 020			Rechter Ständerfuß 8.6	Table leg right 8.6	Pied droit 8.6
3	C4Z 220 030			Mittelteil	Mid-section	Plaque de jonction
4	C4Z 220 040			Spanwanne	Chip tray	Bac à copeaux
5	C4Z 220 050			Tür	Door	Porte
	B2Z 360 030			Linke Tasse 8.4	Holder 8.4	Couvercle grand 8.4
6	C4Z 220 060			Linke Tasse 8.6	Holder 8.6	Couvercle grand 8.6
	B2Z 360 040			Rechte Tasse 8.4	Holder 8.4	Couvercle grand 8.4
7	C4Z 220 070			Rechte Tasse 8.6	Holder 8.6	Couvercle grand 8.6
	B2Z 360 070			Einlageplatte 8.4	Insert 8.4	Tole mitoyen 8.4
8	C4Z 220 080			Einlageplatte 8.6	Insert 8.6	Tole mitoyen 8.6
9	C4Z 220 110			Winkel	Angle plate	Corniere
10	C4Z 220 140			Auflageblech	Face plate	Support bac à copeaux
11	C4Z 220 161			Deckel	Cover	Couvercle
12	C4Z 220 150			Abflügitter	Sink grid	Tamis en fil métallique
13	C4Z 220 090			Gummieinlage	Rubber packing	Piece intercalaire caoutchouc
14	C4Z 220 100			Gummieinlage	Rubber packing	Piece intercalaire caoutchouc
	B2Z 360 050			Moosgummi 8.4	Sectional strandrubber 8.4	Bande caoutchouc d'étancheite 8.4
15	C4Z 220 120			Moosgummi 8.6	Sectional strandrubber 8.6	Bande caoutchouc d'étancheite 8.6
	B2Z 360 060			Moosgummi 8.4	Sectional strandrubber 8.4	Bande caoutchouc d'étancheite 8.4
16	C4Z 220 130			Moosgummi 8.6	Sectional strandrubber 8.6	Bande caoutchouc d'étancheite 8.6
17	ZSR 33 0812	M8x12 DIN 933		Sechskantschraube	Hexagon head screw	Vis 6 pans
18	ZMU34 0800	M8 DIN 934		Mutter	Hexagon nut	Ecrou 6 pans
19	ZRG27 0080	A8 DIN 127		Federring	Spring washer	Rondelle grower
20	ZMU34 0600	M6 DIN 934		Mutter	Hexagon nut	Ecrou 6 pans
21	ZSR 33 1035	M10x35 DIN 933		Sechskantschraube	Hexagon head screw	Vis 6 pans
22	ZSB 25 1050	B10,5 DIN 125		Scheibe	Washer	Rondelle
23	ZSR 33 0508	M5x8 DIN 933		Sechskantschraube	Hexagon head screw	Vis 6 pans
24	ZMU 34 0500	M5 DIN 934		Mutter	Hexagon nut	Ecrou 6 pans
	C4Z 220 170			EMCO - Folie	EMCO	EMCO

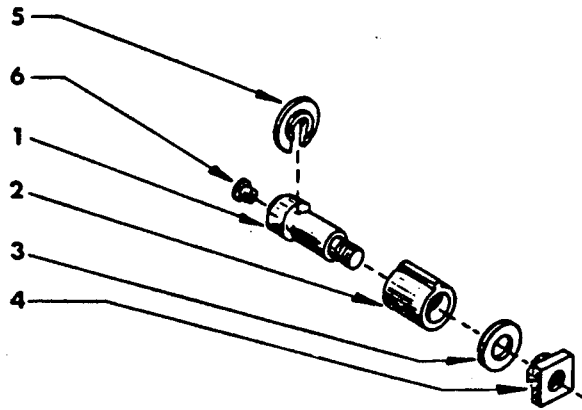

Pos	Ref.No.	DIN	BENENNUNG	DESCRIPTION	DESIGNATION
	B2A 076 000		Gr. Scherbolzen	Shaft	Axe fileté
1	B2A 076 010		Scherbolzen	Shaft	Axe fileté
2	B2A 000 310		Keilhülse	Bush	Bague à clavette
3	B2A 071 020		Scheibe	Washer	Rondelle
4	B2A 071 040		Nutstein	T-nut	Boulon tête carrée
5	B2A 000 450		Sicherungsring	Clip	Bague fendue "Seeger"
6	ZNP 01 1000		Schmiernippel	Grease fitting	Graisseur

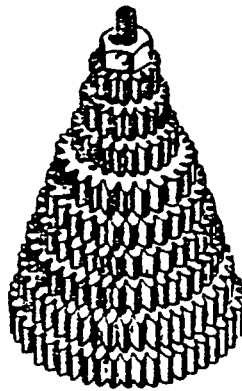

Pos	Ref.No.	DIN	BENENNUNG	DESCRIPTION	DESIGNATION
			Rädersatz	Set of change gears	Jeu d'engrenages
	B2Z 200 010		Wechselrad Z = 25	Change gear	Engrenage
	B2Z 200 020		Wechselrad Z = 30	Change gear	Engrenage
	B2Z 200 030		Wechselrad Z = 40	Change gear	Engrenage
	B2Z 200 040		Wechselrad Z = 45	Change gear	Engrenage
	B2Z 200 050		Wechselrad Z = 50	Change gear	Engrenage
	B2Z 200 060		Wechselrad Z = 55	Change gear	Engrenage
	B2Z 200 070		Wechselrad Z = 60	Change gear	Engrenage
	B2Z 200 080		Wechselrad Z = 65	Change gear	Engrenage
	B2Z 200 090		Wechselrad Z = 70	Change gear	Engrenage



				Vertikalvorrichtung M Vertikalvorrichtung Ww	Vertical attachment M Vertical attachment Ww	Colonne verticale M Colonne verticale Ww
Pos	Ref.No.	DIN		BENENNUNG	DESCRIPTION	DÉSIGNATION
1	B2A 000 020			Bogenfeder	Spring	Ressort
2	B2A 000 100			Mutter	Nut	Ecrou à 2 plats
3	B2A 010 080			Druckfeder	Spring	Ressort
4	B2A 013 000			Kegelgriff	Handle	Manneton
5	B2A 030 090			Gleitstein	Cursor	Curseur
6	B2A 040 040			Handrad	Handwheel	Volant
7	B2A 035 000			Gr. Schalthebel	Lever switch	Manette de commande
8	B2A 035 010			Schalthebel	Lever switch	Manette
9	B2A 035 020			Schaltnabe	Hub	Moyeu
10	E1A 000 010			Sockel	Pedestal	Socle support
11	E2A 000 020			Vertikalsäule	Vertical column	Colonne verticale
12	E2A 000 030			Führungsschiene	Guide rail	Guide verticale
13	E1A 000 040			Vertikalschlitten	Vertical slide	Support poupée coulissant
14	E2A 000 050			Vertikalspindel M	Vertical screw M	Vis mère M
15	E1A 000 060			Vertikalspindel Ww	Vertical screw Ww	Vis mère Ww
16	B2A 000 090			Spindelträger	Lead screw mount	Palier supérieur vis mère
16	B2B 000 090			Skalenring M	Micrometer collar M	Vernier M
17	B2A 000 060			Skalenring Ww	Micrometer collar Ww	Vernier Ww
17	B2B 000 060			Skalenschild M	Plate M	Plaque indicatrice M
18	E1A 000 080			Skalenschild Ww	Plate Ww	Plaque indicatrice Ww
18	E1B 000 080			Vertikalmutter M	Vertical nut M	Ecrou M
19	E1A 000 090			Vertikalmutter Ww	Vertical nut Ww	Ecrou Ww
20	E1A 000 100			Gewinding	Threaded ring	Vis réglage jeu
21	E1A 000 110			Einstellbolzen	Bolt	Vis de réglage
22	E1A 000 120			Druckleiste	Gib	Lardon blocage
23	E1A 000 130			Nutenschraube	T-nut screw	Boulons en T
24	E1A 000 140			Vertikalkopf	Vertical head	Poupée verticale nue
25	E1A 000 150			Achse	Arbor	Axe
26	E1A 000 160			Druckscheibe	Disc	Rondelle intermediaire
27	E1A 000 170			Triebling	Driving point	Axe crante de serrage
28	E1A 000 180			Drehgriff	Turn knob	Bouton molette
29	E1A 000 190			Rückholfeder	Coil spring	Ressort boudin
29	E1B 000 190			Anschlagring M	Stopper M	Piece d'arrêt M
30	E1A 000 220			Anschlagring Ww	Stopper Ww	Piece d'arrêt Ww
31	E1A 000 230			Abdrückmutter	Nut	Ecrou
31	E1B 000 240			Deckel	Cover	Couvercle
32	E1A 000 240			Drehzahlschild (60Hz)	Speed plate	Plaque indicatrice 60 périods
33	E1A 000 250			Drehzahlschild (50Hz)	Speed plate	Plaque indicatrice 50 périods
34	E1A 000 260			Getriebedeckel	Cover	Couvercle supér.-support molette
34	E1B 000 260			Skalenschild M	Plate M	Plaque indicatrice M
35	E1A 000 270			Skalenschild Ww	Plate Ww	Plaque indicatrice Ww
36	E1A 000 280			Schaltstange I	Wipper I	Axe de commande balladeur I
37	E1A 000 290			Schaltstange II	Wipper II	Axe de commande balladeur II
37	E1A 000 290			Stiftschraube	Thread stud	Goujon
38	E1A 010 000			Gr. Pinole	Spindle quill complete	Ensemble fourreau broche
39	E1A 010 010			Pinole	Spindle quill	Fourreau nu
40	E1A 010 020			Spindel	Spindle	Broche
41	E1A 010 030			Mutter	Nut	Bague arret filetée exterieur
42	ZLG 60 0419	6004Y/C3 WM074		Mutter	Nut	Ecrou arret filetée interieur
43	ZLG 81 4013	P6RNA030x40x13		Kugellager	Ball bearing	Roulement à billes
44	ZSB 10 8402	5528x40x2		Nadellager	Needle bearing	Roulement à aiguilles
45	E1A 011 000			Stützscheibe	Washer	Rondelle
45	E1A 011 000			Gr. Schaltrad	Gear wheel	Pignon double

